

GPON HGU with 4-Port GbE, 3000Mbps 802.11AX Wireless

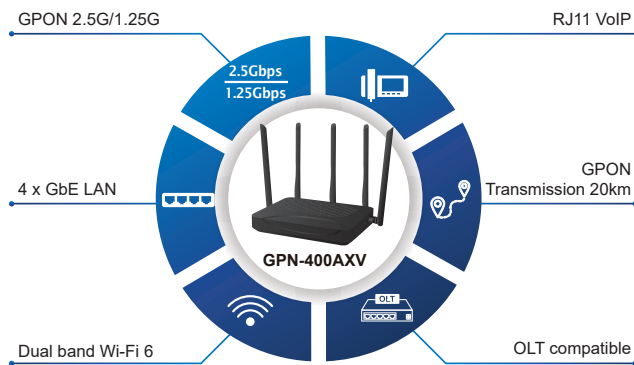

Delivering High-demanding Service Connectivity for ISP / Triple Play Devices

PLANET GPN-400AXV is a high-performance GPON Wi-Fi ONU (optical network unit) equipped with one GPON port, four 10/100/1000Mbps RJ45 LAN ports, one FXS RJ11 voice port, and a USB interface. Featuring IEEE 802.11ax/ac/n Wi-Fi 6 dual-band technology, it delivers exceptional wireless performance up to 3000Mbps. Designed for residential and small business users, it offers an ideal solution for high-speed fiber broadband access and value-added services such as IPTV, VoIP, and ultra-fast Internet. When paired with PLANET GPL-8000 GPON OLT, the GPN-400AXV ensures a **robust and scalable GPON solution** for FTTH deployments.



Fiber To The Home

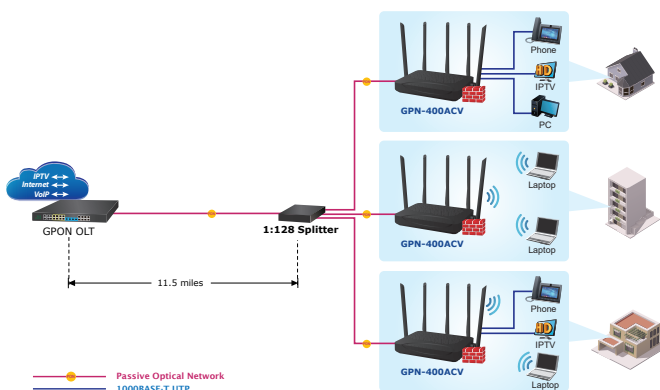

GPON

- 1 x SC/UPC type GPON port (compatible with EPON)
- Up to 2.5Gbps downstream and 1.25Gbps upstream
- Transmission distance up to 20km
- Optical transmit power: 0.5~5dBm, receive sensitivity: ≤ -28dBm
- Supports ITU-T G.984 / G.988, IEEE802.3ah standards
- Automatic switching between EPON and GPON for hybrid deployment

Ethernet

- 802.1Q VLAN, and QoS for virtual LAN tagging and traffic prioritization
- Broadcast storm protection to prevent and limit broadcast traffic
- Bandwidth control to manage and allocate network bandwidth
- IGMP snooping/proxy for efficient multicast traffic management
- IPv4 and IPv6 protocols supported

VoIP

- 1 FXS port, supporting SIP and H.248 protocols
- Compatible with voice codecs including G.711, G.729 and G.723
- Supports T.38 and G.711 pass-through for fax

Wireless

- Up to 3000Mbps bandwidth
- Compatible with 802.11ax Wi-Fi 6
- Backward compatible with 802.11b/g/n/ac
- Compatible to equipment working on 2.4GHz and 5GHz

QoS

- IEEE 802.3x flow control for full-duplex communication
- Queue scheduling algorithms including WRR, Strict Priority, and FIFO

Multicast

- IGMP snooping v1/v2/v3

Wi-Fi 6 AX3000 Delivers Reliable Wireless Performance

With built-in dual-band Wi-Fi 6 and five external antennas, the GPN-400AXV supports a total wireless speed of up to 3000Mbps. It supports MIMO technology, offering **greater capacity and lower latency**, ideal for modern smart home and office environments.

Flexible Gigabit LAN and USB Connectivity

Four Gigabit Ethernet ports and one USB interface ensure **fast and stable wired connections** for devices like desktops, NAS, and smart TVs. The USB port also supports additional use cases such as file sharing or storage applications.

Built-in FXS Voice Port

The GPN-400AXV includes one FXS port supporting SIP and H.248 protocols. This allows integration into IP voice systems and helps reduce call costs for **long-distance and remote office communications**.

IPv4 and IPv6 Dual Stack Capability

The device is fully compatible with both IPv4 and IPv6, making it a **future-proof choice for ISPs** planning IPv6 migration.

Comprehensive Management and Security

It supports Web GUI, Telnet, TR-069, OMCI, and OAM management methods, plus firmware upgrades via remote platforms. Integrated firewall and ACL features ensure **network security and reliable operation**.

- IGMP proxy function

Security

- Firewall with MAC/IP/Port/URL/Domain filtering
- DDoS attack protection

Wireless

- Up to 3000Mbps bandwidth
- Compatible with 802.11ax Wi-Fi 6
- Backward compatible with 802.11b/g/n/ac
- Compatible to equipment working on 2.4GHz and 5GHz

Physical Hardware

- 4 x 10/100/1000Mbps Gigabit Ethernet ports
- 1 x FXS voice port
- 1 x USB interface
- 5 x external antennas (for 2.4GHz and 5GHz)
- Dimensions: 185 x 135 x 36mm (excluding antennas)
- Power input: DC 12V / 1.5A, power consumption < 18W

Features

- Dynamic Bandwidth Allocation (DBA) support
- IEEE 802.3x flow control
- WR, SP, and FIFO queue scheduling algorithms for traffic management
- Port-based VLAN and IEEE 802.1Q VLAN
- Firewall like MAC/IP/Port/URL/Domain filtering
- DDoS protection to safeguard against distributed denial-of-service attacks
- Loop detection to prevent network loops
- Dying-gasp mechanism for graceful device shutdown
- Type B dual-homing protection

Management

- Web, Telnet, TR-069, OMCI, and OAM remote management
- Firmware upgrade via TFTP, Web, TR-069, and OLT

Applications

Reliable GPON Connectivity for Residential Triple-Play and FTTH Services

PLANET GPN-400AXV is a fully integrated GPON ONU that combines high-speed fiber access, Gigabit Ethernet, dual-band Wi-Fi 6, and voice functionality, making it ideal for smart homes, SOHO environments, and commercial spaces. Supporting both GPON technology with 2.5Gbps downstream and 1.25Gbps upstream transmission, it also features AX3000-class Wi-Fi 6, providing simultaneous 2.4GHz and 5GHz bands to ensure smooth and stable connections across multiple devices.

Whether deployed in high-density residential communities, hotels, or small to medium-sized businesses, the GPN-400AXV delivers reliable network performance and flexible management. With advanced features such as VLAN, QoS, ACL, and firewall support, it secures internal networks and prioritizes critical services. It secures internal networks and prioritizes critical services while delivering reliable dual-band Wi-Fi 6 performance for modern home and business environments.

In addition, the built-in FXS port supports SIP and H.248 protocols, allowing for easy integration with residential or enterprise VoIP systems, reducing deployment complexity and costs. When paired with PLANET OLT solutions, the GPN-400AXV enables rapid FTTH network deployment, making it the perfect choice for high-performance, intelligent networking.



Specifications

Products	GPN-400AXV
Hardware Specifications	
UNI port	4 x 10/100/1000BASE-T RJ45 copper Wi-Fi 6 external 5 antennas (2.4GHz x 2, 5GHz x 3) 1 x USB 2.0 host port 1 x RJ11 FXS port
PON port	Transmission rate: 2.5Gbps downlink / 1.25Gbps uplink Network Coverage Radius: 20 kilometers Receiver Sensitivity: ≤-28dBm Transmit Optical Power: 0.5~5dBm Optical interface type: SC/UPC
Button	1 x power ON/OFF button 1 x reset button (Press for about 15 seconds to reset the device to factory default.) 1 x WLAN enable/disable button 1 x WPS enable/disable button 1 x LED on/off button
Thermal Fan	Fanless
LED Indicators	PWR (Green) LOS/PON (Red)/(Green) Internet (Green) LAN1-LAN4 (Green) VoIP (Green) Wi-Fi (Green) WPS (Green) USB (Green)
Installation	Desktop installation or wall mounting
Power Requirements	12V DC, 1.5A max.
Power Consumption	18W max.
Weight	500g
Enclosure	Plastic
Wi-Fi	802.11b/g/n/ac/ax MIMO, with a maximum rate of 3000Mbps. multiple SSIDs and SSID encryption
Dimensions (WxDxH)	244.3 x 162.15 x 193 mm (including antennas)
Heat dissipation	Extended use (24 hours) does not result in performance degradation or damage due to device overheating or deformation.
Wireless Interface Specifications	
Standard	IEEE 802.11ax 5GHz IEEE 802.11ax 2.4GHz IEEE 802.11a/b/g/n/ac compatible
Frequency Band	Simultaneous 2.4GHz and 5GHz
Modulation Type	802.11ax: OFDMA (BPSK / QPSK / 16QAM / 64QAM / 256QAM / 1024QAM) 802.11n/g/a: OFDM 802.11b: DSSS (DBPSK / DQPSK / CCK)
Data Transmission Rates	2.4GHz up to 574Mbps 5GHz up to 2402Mbps @ 160MHz)
Channel	2.4GHz: FCC (America): 2.412~2.462GHz (11 Channels) ETSI (Europe): 2.4122.472GHz (13 Channels) 5.180~5.825GHz (up to 24 channels, depending on country)
Channel Width	802.11ax: 20/40/80/160MHz
Max. RF Power / EIRP	2.4GHz: < 20dBm 5GHz: < 23dBm (varies by region)
Wireless Management Features	
Encryption Security	64/128-bit WEP, WPA, WPA2-PSK, WPA3-SAE
Wireless Security	SSID broadcast enable/disable Wireless MAC address filtering WPS (Wi-Fi Protected Setup) support Client isolation

Wireless Advanced	<ul style="list-style-type: none"> Transmit power adjustment Beacon interval configuration WMM (Wi-Fi Multimedia) support Band steering (2.4GHz/5GHz auto-switch) Wi-Fi schedule
Max. Supported Clients	Up to 128 wireless clients
Router Features	
Data Forwarding	Routing Mode, Bridging Mode, and Routing + Bridging Hybrid Mode
DNS	DNS Relay
DHCP	DHCP server
VLAN	<ul style="list-style-type: none"> Port-based VLAN IEEE 802.1Q VLAN
Multicast	<ul style="list-style-type: none"> Supports IGMP Snooping Supports CTC-defined dynamic multicast Supports MLD Snooping Supports Full-Routing Multicast
QoS	<ul style="list-style-type: none"> Backpressure Flow Control (Half-Duplex) IEEE 802.3x Flow Control (Full-Duplex) Preventing Head-of-Line Blocking IEEE 802.1p, CoS 8 Priority Queues per Port WR, SP, and FIFO Port Rate Limiting
Reliability	<ul style="list-style-type: none"> Loop Detection Dying-Gasp Type B Dual Homing Protection
Security	<ul style="list-style-type: none"> Port MAC Address Limitation Port Protection Port Storm Suppression Supports firewall MAC/IP/Port/URL/Domain filtering Supports DDoS protection
Management Configuration	<ul style="list-style-type: none"> Web, TELNET, TR069, OMCI Software Upgrade through TFTP, WEB, TR069, and OLT
VoIP Protocols and Standard	
Standard	T.38 (G.711 Fax pass-through)
Voice Codec	G.711A/G.711U/G.723/G.729
Voice Standard	VAD (Voice Activity Detection)
Standards Conformance	
Standards	<ul style="list-style-type: none"> ITU-T G.987.3, G.988 IEEE 802.1Q, VLAN
Environment Specifications	
Operating	<ul style="list-style-type: none"> Temperature: 0 ~ 50 degrees C Relative Humidity: 5 ~ 95% (non-condensing)
Storage	<ul style="list-style-type: none"> Temperature: -10 ~ 60 degrees C Relative Humidity: 5 ~ 95% (non-condensing)

Dimensions

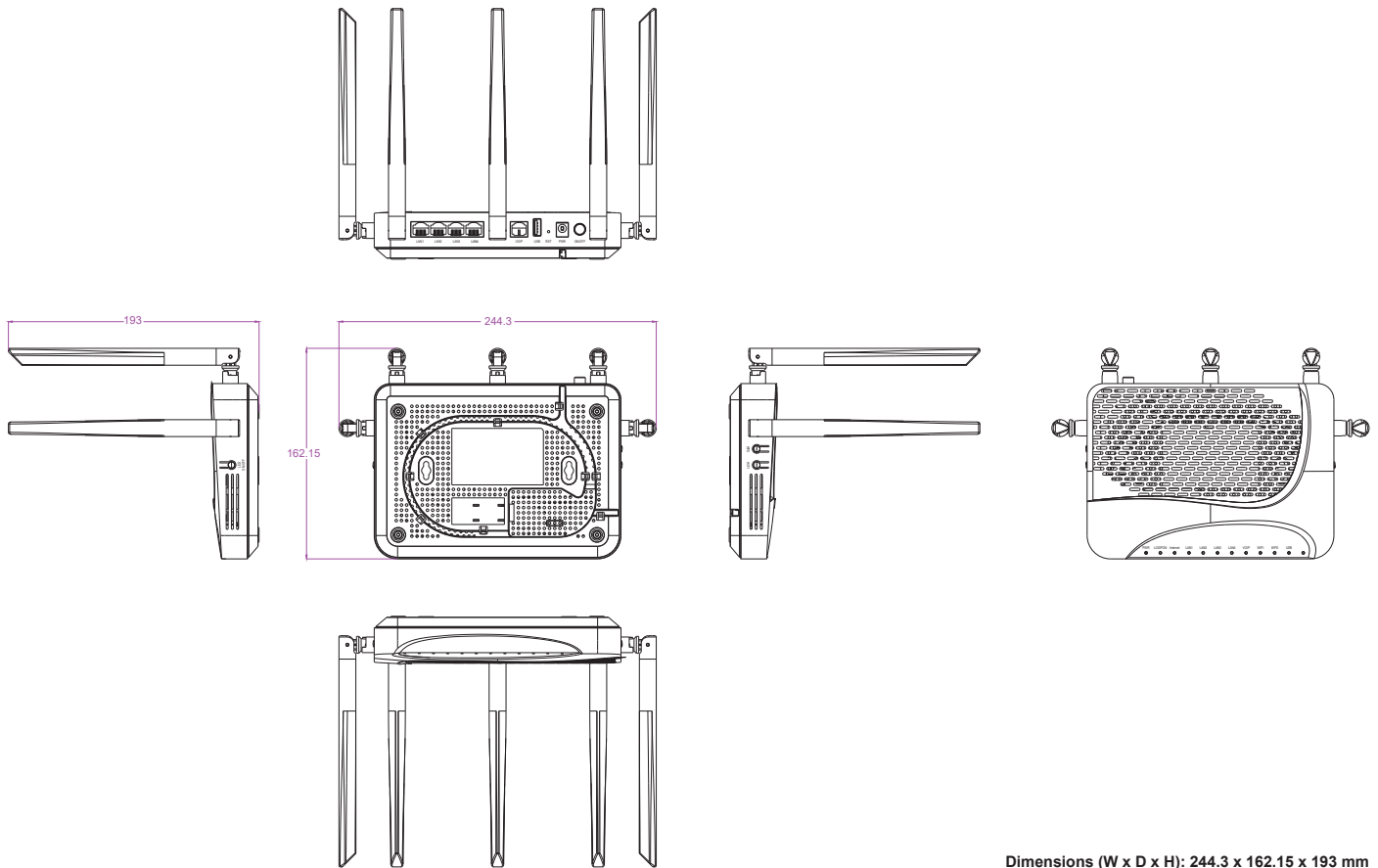

Dimensions (W x D x H): 244.3 x 162.15 x 193 mm

Ordering Information

GPN-400AXV	GPON HGU with 4-Port GbE, 3000Mbps 802.11AX Wireless and 1-Port FXS
------------	---

Related Products

GPL-8000	2-PON-Port GPON OLT with 2 1000BASE-X SFP Uplink Slots
CS6-16PON4C4S4X	16-Port xPON + 4-Port Gigabit TP/SFP + 4-Port 1000BASE-X SFP + 4-Port 10GBASE-X SFP+ Management Module for CS-6303R and CS-6306R
GPN-100	GPON SFU ONT with 1 GbE Interface
GPN-SFP	GPON ONU SFP Transceiver
XGPL-16000	16-Port XGS-PON OLT with 8-Port 10G SFP+ + 2-Port 100G QSFP28
XGPN-400AXV	XG-PON HGU with 4-Port GbE, 3000Mbps 802.11AX Wireless and 1-Port FXS

PLANET Technology Corporation

11F., No.96, Minquan Rd., Xindian Dist., New Taipei City 231, Taiwan (R.O.C.)

Tel: 886-2-2219-9518

Email: sales@planet.com.tw

Fax: 886-2-2219-9528

www.planet.com.tw



PLANET reserves the right to change specifications without prior notice. All brand names and trademarks are property of their respective owners. Copyright © 2025 PLANET Technology Corp. All rights reserved.

GPN-400AXV