

User's Manual



**8-/16-/24-Port 10Gbps 802.3bt PoE++
Managed Injector Hub**

▶ **UPOE-800XG/UPOE-1600XG/UPOE-2400XG**



Trademarks

Copyright © PLANET Technology Corp. 2026.

Contents are subject to revision without prior notice.

PLANET is a registered trademark of PLANET Technology Corp. All other trademarks belong to their respective owners.

EU Representative

PLANET Technology Europe B.V.

Address: Posthoornstraat 11, 3011 WD Rotterdam, NL

Email: eu_rep@planet.com.tw

URL: www.planet.com.tw

Disclaimer

PLANET Technology does not warrant that the hardware will work properly in all environments and applications, and makes no warranty and representation, either implied or expressed, with respect to the quality, performance, merchantability, or fitness for a particular purpose. PLANET has made every effort to ensure that this User's Manual is accurate; PLANET disclaims liability for any inaccuracies or omissions that may have occurred.

Information in this User's Manual is subject to change without notice and does not represent a commitment on the part of PLANET. PLANET assumes no responsibility for any inaccuracies that may be contained in this User's Manual. PLANET makes no commitment to update or keep current the information in this User's Manual, and reserves the right to make improvements to this User's Manual and/or to the products described in this User's Manual, at any time without notice.

If you find information in this manual that is incorrect, misleading, or incomplete, we would appreciate your comments and suggestions.

FCC Warning

This equipment has been tested and found to comply with the limits for a Class A digital device, pursuant to Part 15 of the FCC Rules. These limits are designed to provide reasonable protection against harmful interference when the equipment is operated in a commercial environment. This equipment generates, uses, and can radiate radio frequency energy and, if not installed and used in accordance with the Instruction manual, may cause harmful interference to radio communications. Operation of this equipment in a residential area is likely to cause harmful interference in which case the user will be required to correct the interference at his own expense.

Warning:

1) This device must be earthed. 2) For indoor use only!

CE Mark Warning

This device is compliant with Class A of CISPR 32. In a residential environment this equipment may cause radio interference.

Energy Saving Note of the Device

This power required device does not support Standby mode operation. For energy saving, please remove the power cable to disconnect the device from the power circuit. In view of saving the energy and reducing the unnecessary power consumption, it is strongly suggested to remove the power connection for the device if this device is not intended to be active.

WEEE Warning



To avoid the potential effects on the environment and human health as a result of the presence of hazardous substances in electrical and electronic equipment, end users of electrical and electronic equipment should understand the meaning of the crossed-out wheeled bin symbol. Do not dispose of WEEE as unsorted municipal waste and have to collect such WEEE separately.

Revision

PLANET 8-/16-/24-Port 10Gbps 802.3bt PoE++ Managed Injector Hub User's Manual

FOR MODELS: UPOE-800XG, UPOE-1600XG, UPOE-2400XG

REVISION: 1.0 (MARCH, 2026)

Part No.: EM-UPOE-800XG_1600XG_2400XG_v1.0

TABLE OF CONTENTS

1. INTRODUCTION	6
1.1 PACKAGE CONTENTS	6
1.2 PRODUCT DESCRIPTION	7
1.3 HOW TO USE THIS MANUAL	13
1.4 PRODUCT FEATURES	14
1.5 PRODUCT SPECIFICATIONS	16
2. INSTALLATION	19
2.1 HARDWARE DESCRIPTION	19
2.1.1 Injector Front Panel	19
2.1.2 LED Indicators	21
2.1.3 Injector Rear Panel	24
2.2 INSTALLING THE 10GBPS 802.3BT PoE++ MANAGED INJECTOR HUB	25
2.2.1 Desktop Installation	25
2.2.2 Rack Mounting	27
2.2.3 Network Application Installation	28
2.2.4 Power over Ethernet Powered Device	29
3. Management	30
3.1 OVERVIEW	30
3.2 REQUIREMENTS	30
3.3 MANAGEMENT METHOD	31
3.3.1 Web Management	31
3.3.2 PLANET Smart Discovery Utility	34
4 WEB CONFIGURATION	36
4.1 MAIN MENU	36
4.2 SYSTEM	38
4.2.1 System Information	39
4.2.2 System Service	40
4.2.3 Connection Status	41
4.2.4 SNMP	42
4.2.5 NMS	44
4.2.6 Radius	52
4.2.7 Remote Syslog	53
4.2.8 Event Log	54
4.3 NETWORK	55
4.3.1 LAN	56

4.3.2 IPv6	57
4.3.3 LLDP	58
4.3.4 DDNS	59
4.4 SECURITY	61
4.4.1 Firewall	62
4.4.2 Authentication.....	64
4.4.3 MAC Filtering.....	65
4.4.4 Access Management.....	66
4.4.5 Certificates	68
4.5 PoE	69
4.5.1 PoE Configuration	70
4.5.2 PoE Status	73
4.5.3 PoE Schedule.....	74
4.5.4 PoE Alive Check.....	76
4.6 MAINTENANCE	78
4.6.1 Administrator	79
4.6.2 Date and Time.....	80
4.6.3 Saving/Restoring Configuration	81
4.6.4 Firmware Upgrade	82
4.6.5 Reboot/Reset	83
4.6.6 Auto Reboot	84
4.6.7 Diagnostics.....	85
5. Power OVER Ethernet Overview.....	87
6. The PoE Provision Process	89
6.1 LINE DETECTION	90
6.2 CLASSIFICATION.....	90
6.3 START-UP.....	90
6.4 OPERATION	90
6.5 POWER DISCONNECTION SCENARIOS.....	91
APPENDIX A.....	92
A.1 MDI SETTINGS	92
A.2 POWER DEVICE CLASSIFICATION VALUES	92
A.3 DATA OUT PoE INJECTOR RJ45 PORT PIN ASSIGNMENTS	93

1. INTRODUCTION

Thank you for purchasing PLANET 8-/16-/24-Port 10Gbps 802.3bt PoE++ Managed Injector Hub, UPOE-800XG/UPOE-1600XG /UPOE-2400XG.

The descriptions of this series are shown below:

UPOE-800XG 8-Port 10Gbps 802.3bt PoE++ Managed Injector Hub (400 watts)

UPOE-1600XG 16-Port 10Gbps 802.3bt PoE++ Managed Injector Hub (600 watts)

UPOE-24X00G 24-Port 10Gbps 802.3bt PoE++ Managed Injector Hub (800 watts)

Model Name	10/100/1000/ 2.5G/5G/10GBASE-T Power Output Ports	10/100/1000/ 2.5G/5G/10GBASE-T Data Input Ports	10/100/1000T RJ45 Management Port	Max. PoE Budget
UPOE-800XG	8	8	1	400 watts
UPOE-1600XG	16	16	1	600 watts
UPOE-2400XG	24	24	1	800 watts

1.1 Package Contents

Open the box of the 10Gbps 802.3bt PoE++ Managed Injector Hub and carefully unpack it. The box should contain the following items:

- The 10Gbps 802.3bt PoE++ Managed Injector Hub x 1
- QR Code Sheet x 1
- CloudNMS App Quick Guide x1
- Power Cord x 1
- Rubber Feet x 4
- 19" Rack-mounting Brackets x 2

If any of these are missing or damaged, please contact your dealer immediately; if possible, retain the carton including the original packing material, and use them again to repack the product in case there is a need to return it to us for repair.

In the following sections, the term "**10Gbps 802.3bt PoE++ Managed Injector Hub**" mentioned in this user's manual refers to the UPOE-800XG, UPOE-1600XG or UPOE-2400XG.

1.2 Product Description

PLANET's 10Gbps 802.3bt PoE++ Managed Injector Hub series offers a high-density, rack-mountable solution for rapid 10Gbps PoE++ deployment. It is designed to seamlessly upgrade existing network infrastructures to the IEEE 802.3bt standard without the need to replace current Ethernet Switch devices.

To ensure robust cybersecurity, the 10Gbps 802.3bt PoE++ Managed Injector Hub series features enhanced management functions, including TLSv1.2 and TLSv1.3 protocols.

Furthermore, through integration with PLANET's NMSViewerPro/CloudNMS apps, all kinds of businesses can efficiently manage their entire network from a single, centralized platform. This 10Gbps 802.3bt PoE++ Managed Injector Hub series also supports PLANET DDNS/Easy DDNS services for flexible remote access.

A Perfect Managed PoE++ Injector Hub with Full Power Budget

The 10Gbps 802.3bt PoE++ Managed Injector Hub series, a high-density, rack-mountable managed IEEE 802.3bt PoE++ injector hub, features PLANET intelligent PoE functions through web user interface for remote management. It provides 8/16/24 10/100/1000/2.5G/5G/10GBASE-T Ethernet ports featuring 802.3bt type-4 PoE++ injector with a total PoE budget of 400/600/800 watts. Each PoE port can deliver up to 95-watt power over Cat.5/5e/6/7 Ethernet UTP cables which allow data and power to transmit simultaneously to a remote 802.3bt/at powered device (PD).

The 10Gbps 802.3bt PoE++ Managed Injector Hub series enables centralization of the power supply and optimizes the installation and power management of remote network devices, and provides a quick, safe and effective Power over Ethernet network solution for small businesses and enterprises.

Model	PoE Ports	Per PoE Power Output	PoE Standard	Total PoE Budget
UPOE-800XG	8	95 watts	IEEE 802.3bt PoE++ IEEE 802.3at PoE+	400 watts
UPOE-1600XG	16			600 watts
UPOE-2400XG	24			800 watts

802.3bt PoE++ 95-watt Power over 4-pair UTP Solution

As the 10Gbps 802.3bt PoE++ Managed Injector Hub series adopts the IEEE 802.3bt PoE++ standard technology, it is capable to source up to 95 watts of power by using all the four pairs of standard Cat.5/5e/6/7 Ethernet cabling to deliver power and full-speed data to each remote PoE compliant powered device (PD). Its power capability is three times more than that of the conventional 802.3at PoE+ and it is an ideal solution for those high power consuming network PDs, such as:

- PoE PTZ speed dome cameras
- Network devices
- Thin clients
- AIO (all-in-one) touch PCs, point of sale (POS) and information kiosks
- Remote digital signage displays
- PoE lightings



802.3bt PoE++ and Advanced PoE Power Output Mode Management

To meet the demand of various powered devices consuming stable PoE power, the 10Gbps 802.3bt PoE++ Managed Injector Hub series supports multi-PoE operation modes that include 95-watt 802.3bt type-4 PoE++ mode, and 4-pair legacy and force modes to solve the incompatibility of non-standard 4-pair PoE PDs in the field.

- 95W 802.3bt PoE++ Power Output Mode
- 36W End-span 802.3at PoE+ Power Output Mode
- 36W Mid-span 802.3at PoE+ Power Output Mode

PoE Watts	PoE Operation Mode	Power Output Mode
95W	802.3bt PoE++	(Pins 1, 2, 3, 6 + Pins 4, 5, 7, 8)
36W	End-span 802.3at PoE	(Pins 1, 2, 3, 6)
36W	Mid-span 802.3at PoE	(Pins 4, 5, 7, 8)

Selectable End-span/Mid-span/802.3bt PoE++ Power Inline Mode

Port	Description	PoE Function	Schedule	Power Mode	Power Type	Priority	Device Class	Current Used [mA]	Powered Used [W]	Power Limit [W]
All		<All>	<All>	<All>	<All>	<All>				
1		Enable	None	BT	Standard	High	--	0	0	95
2		Enable	None	BT	Standard	High	--	0	0	95
3		Enable	None	BT	Standard	High	--	0	0	95

Standard
Legacy
Force

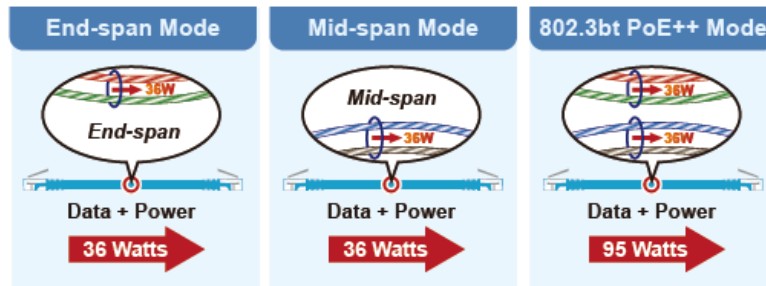

Quick and Easy 802.3bt/at PoE Network Deployment

The 10Gbps 802.3bt PoE++ Managed Injector Hub series is installed between a regular Ethernet Switch and the PDs. There are totally 16/32/48 RJ45 STP ports on the front panel of the 10Gbps 802.3bt PoE++ Managed Injector Hub series, of which the 8/16/24 ports are on the lower stack functioned as "Data input" while the other 8/16/24 ports are on the upper stack functioned as "PoE (Data and Power) output". Both power and data are transferred simultaneously over the UTP cables to PDs without affecting the existing network performance and functions.

With data and Power over Ethernet from one unit, the 10Gbps 802.3bt PoE++ Managed Injector Hub series can reduce power cable deployment and eliminate the need for dedicated electrical outlets on the wall, ceiling or any unreachable place.

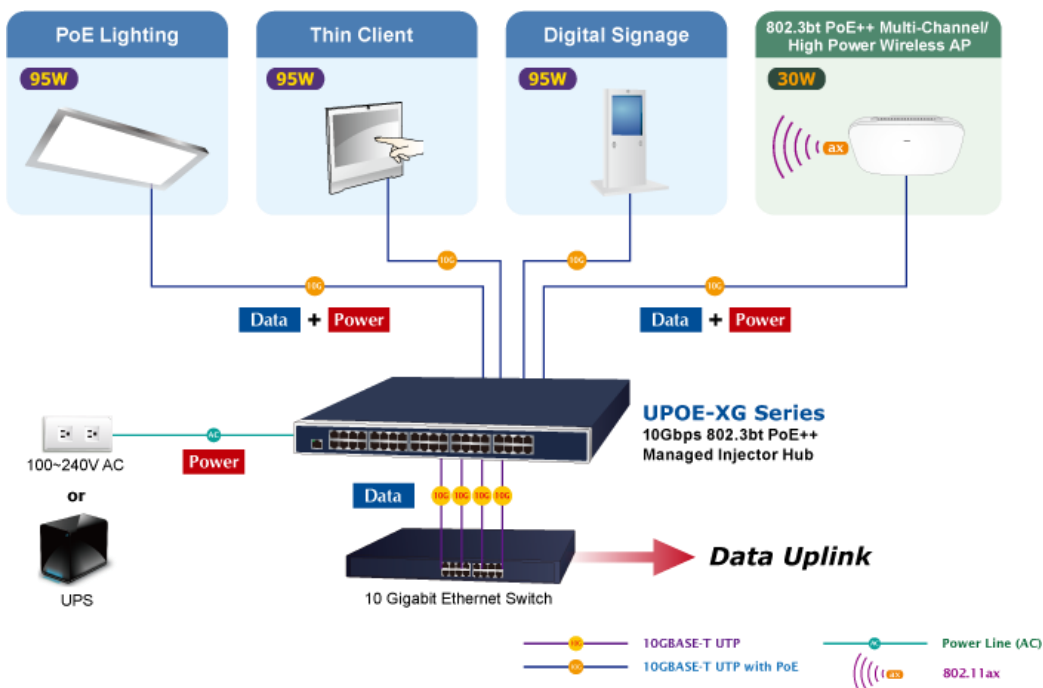

Built-in Unique PoE Functions for Powered Device Management

As it is the 10Gbps Managed PoE++ Injector Hub for surveillance, wireless and VoIP networks, the 10Gbps 802.3bt PoE++ Managed Injector Hub series features the following special PoE management functions:

- PoE schedule
- PD alive check
- Scheduled power recycling
- PoE usage monitoring

Intelligent Powered Device Alive Check

The 10Gbps 802.3bt PoE++ Managed Injector Hub series can be configured to monitor connected PD status in real time via ping action. Once the PD stops working and responding, the 10Gbps 802.3bt PoE++ Managed Injector Hub series will resume the PoE port power and bring the PD back to work. It will greatly enhance the network reliability through the PoE port resetting the PD's power source and reducing administrator management burden.

PD Alive Check

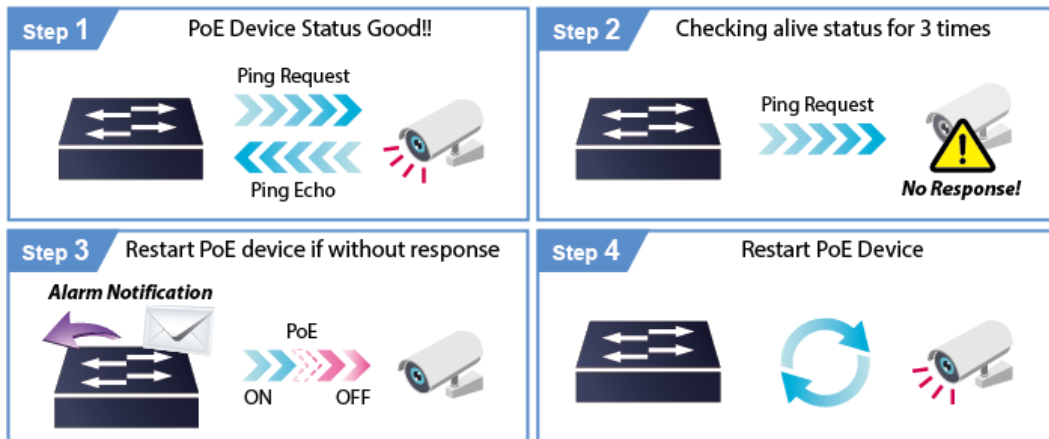

PoE Schedule for Energy Savings

Under the trend of energy savings worldwide and contributing to environmental protection on the Earth, the 10Gbps 802.3bt PoE++ Managed Injector Hub series can effectively control the power supply besides its capability of giving high watts power. The built-in "PoE schedule" function helps you to enable or disable PoE power feeding for each PoE port during specified time intervals and it is a powerful function to help SMBs or enterprises save power and money.

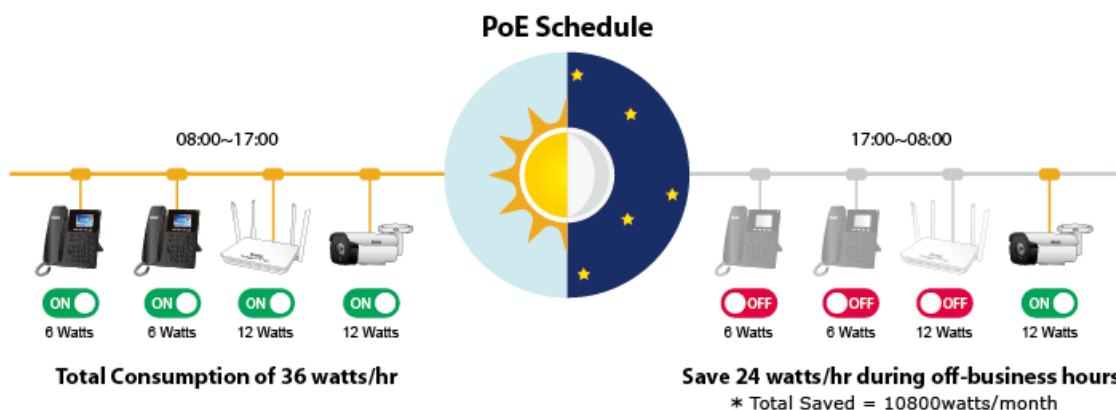

Scheduled Power Rebooting

The 10Gbps 802.3bt PoE++ Managed Injector Hub series can be scheduled to reboot at a specified time like every minute, every hour, every day to reduce the chance of PD device crash resulting from buffer overflow.

PoE Usage Monitoring

Via the power usage chart in the web management interface, the 10Gbps 802.3bt PoE++ Managed Injector Hub series enables the administrator to monitor the status of the power usage of the connected PDs in real time. Thus, it greatly enhances the management efficiency of the facilities.

High Power Budget for PoE Extension

With up to 95-watt PoE output capability, the 10Gbps 802.3bt PoE++ Managed Injector Hub series can extend much longer distance by using PLANET PoE Extender for powering up the PoE PD which can be installed over more than 100 meters away. By daisy-chaining multiple PLANET 802.3bt PoE++ Extenders, it offers the great flexibility of doubling, tripling or quadrupling the distance of PoE network.

Smart Fan Design for Silent Operation

The 10Gbps 802.3bt PoE++ Managed Injector Hub series features a low noise design and an effective ventilation system. It supports the smart fan technology that automatically controls the speed of the built-in fan to reduce noise and maintain the temperature of the PoE injector hub for optimal power output capability, with low speed and high speed smart fan status display on web interface. The 10Gbps 802.3bt PoE++ Managed Injector Hub series is able to operate reliably, stably and quietly in any environment without affecting its performance.

Cybersecurity Network Solution to Minimize Security Risks

The cybersecurity feature included to protect the 10Gbps 802.3bt PoE++ Managed Injector Hub series management in a mission-critical network virtually needs no effort and cost to install. Both TLSv1.2 and TLSv1.3 protocols are utilized to provide strong protection against advanced threats. The network administrator can now construct highly-secure corporate networks with considerably less time and effort than before.



User-friendly Web Management Interface

To efficiently manage the PDs, the 10Gbps 802.3bt PoE++ Managed Injector Hub series provides simple Web management interface in which administrators can control the system and PoE functions for PDs. It can automatically detect the power status of each port and show messages on its Web management interface. These features also provide users with a cost-effective way to manage the device via Internet whenever they are at work or at home.

PLANET CloudNMS – Cloud-Based Universal Network Management

PLANET's CloudNMS platform and mobile app empower IT staff to remotely manage all network devices and Powered Devices (PDs) in real time. Designed for enterprises and industries, CloudNMS minimizes the need for on-site troubleshooting by providing centralized monitoring, fault detection, and instant alerts.

With CloudNMS, businesses can manage diverse network deployments more efficiently, securely, and intelligently—all from a single cloud-based platform.



1.3 How to Use This Manual

This User Manual is structured as follows:

- **Section 2, Installation**

It explains the functions of 10Gbps 802.3bt PoE++ Managed Injector Hub and how to physically install the 10Gbps 802.3bt PoE++ Managed Injector Hub.

- **Section 3, Management**

It contains information about the software function of the 10Gbps 802.3bt PoE++ Managed Injector Hub.

- **Section 4, Web Configuration**

The section explains how to manage the 10Gbps 802.3bt PoE++ Managed Injector Hub through Web interface.

- **Section 5, Power over Ethernet overview**

The section explains the Power over Ethernet theories.

- **Section 6, PoE Power Provision Process**

The section explains the PoE power provision process.

- **Appendix A**

It contains cable information of 10Gbps 802.3bt PoE++ Managed Injector Hub.

1.4 Product Features

➤ **Interface**

■ **16/32/48-port RJ45**

- 8/16/24-port 10/100/1000/2.5G/5G/10GBASE-T "Data input"
- 8/16/24-port 10/100/1000/2.5G/5G/10GBASE-T "Data + Power output"

- One 10/100/1000BASE-T management port

➤ **802.3bt Power over Ethernet**

- Complies with IEEE 802.3bt Power over Ethernet Plus Plus
- Backward compatible with IEEE 802.3at Power over Ethernet Plus
- Up to 8/16/24 ports of IEEE 802.3at/IEEE 802.3bt PoE devices powered
- 8/16/24 PoE ports with built-in 802.3bt type-4 PoE 95W injector function
- All PoE ports support 802.3at end-span/mid-span PoE 36W injector function
- Auto detects powered device (PD)
- Circuit protection prevents power interference between ports
- Remote power feeding up to 100 meters

➤ **PoE Management**

- PoE admin-mode control
- PoE Consumption and allocation mode option
- Per port PoE function enable/disable
- Per port PoE Inline mode option (802.3BT(Factory default)/End-span/Mid-span)
- Per port PD type option (Standard(Factory default)/Legacy/Force)
- PoE port power feeding priority
- PD classification detection
- PoE schedule
- PD alive check

➤ **Security**

- SPI Firewall Protection
- Authentication Method Configuration
- MAC Filtering
- Access Management for HTTP/HTTPS/SNMP
- System CA Certificate for HTTPS

➤ **Management**

- IPv4 and IPv6 dual stack management
- Web interface for remote management
- LLDP Link Layer Discovery Protocol (LLDP)
- PLANET DDNS and Easy DDNS
- Supports Network Time Protocol (NTP)
- System Maintenance
 - Firmware upload via HTTP
 - Configuration upload/download via HTTP
 - Reboot button for system reboot
 - Reset button for system reset to factory default
- PLANET Smart Discovery utility automatically finds PLANET devices on the network
- PLANET NMS system and CloudNMS for deployment management
- Remote RADIUS Server authentication
- SNMP v1, v2c and v3 for system status monitoring
- SNMP trap for alarm notification of events
- System event log/remote syslog
- Scheduled System Power Rebooting
- Network Diagnostic
 - ICMPv6/ICMPv4 Remote Ping
 - Trace Route

➤ **Hardware**

- 19-inch rack mountable; 1U height
- Reset button for resetting to default setting and system reboot
- LED indicators for PoE ready and PoE activity
- LED indicators for power alert and fan alert
- FCC Part 15 Class A, CE

1.5 Product Specifications

Product	UPOE-800XG	UPOE-1600XG	UPOE-2400XG	
Hardware				
Interface	Management Port	1 x RJ45; 10/100/1000BASE-T, auto-negotiation, auto-MDI/MDIX		
	“Data” Input Ports	8 x RJ45	16 x RJ45	24 x RJ45
	“Data + Power” Output Ports	8 x RJ45	16 x RJ45	24 x RJ45
Data Rate	10/100/1000/2.5G/5G/10GBASE-T			
Power Requirements	100-240V AC, 50/60 Hz, 6.5A	100-240V AC, 50/60 Hz, 12A	100-240V AC, 50/60 Hz, 15A	
Power Consumption	Max. 11.5 watts / 39.2 BTU (Power on without any connection)	Max. 13.8 watts / 47 BTU (Power on without any connection)	Max. 39.7 watts / 135.4 BTU (Power on without any connection)	
	Max. 455 watts / 1552 BTU (Full Loading)	Max. 677 watts / 2309BTU (Full Loading)	Max. 944 watts / 3220 BTU (Full Loading)	
Ventilation	Smart Fan x 3			
Dimensions (W x D x H)	440 x 301 x 44mm			
Weight	3.8kg	4.4kg	5.3kg	
Reset Button	< 5 sec: System reboot > 5 sec: Factory default			
LED	System: SYS PWR x 1 (Green) PoE Alarm x 1 (Red) Fan Alarm x 2 (Red) Management port x 1: LNK/ACT (Green), Per PoE Port: 802.3bt PoE-in-use x 1 (Green) 802.3at/af PoE-in-use x1 (Amber)			
Network Cable	10BASE-T: 4-pair UTP Cat5 up to 100m (328ft) 100BASE-TX: 4-pair UTP Cat5 up to 100m (328ft) 1G/2.5GBASE-T: 4-pair UTP Cat 5e/Cat 6/Cat 6A/Cat 7 up to 100m (328ft) 5GBASE-T: 4-pair UTP Cat 6/Cat 6A/Cat 7 up to 100m (328ft) 10GBASE-T: 4-pair UTP Cat 6A/Cat 7 up to 100m (328ft) EIA/TIA- 568 100-ohm STP (100m)			
Power over Ethernet				
PoE Standard	802.3bt PoE++ PSE Backward compatible with IEEE 802.3at PoE PSE			
PoE Power Supply Mode	<ul style="list-style-type: none"> ■ 802.3bt ■ End-span ■ Mid-span 			
PoE Power Output	Per port 54V DC <ul style="list-style-type: none"> ■ 802.3bt mode: maximum 95 watts ■ End-span mode: maximum 36 watts ■ Mid-span mode: maximum 36 watts 			

Power Pin Assignment	<ul style="list-style-type: none"> ■ 802.3bt: 1/2(-), 3/6(+), 4/5(+), 7/8(-) ■ End-span: 1/2(-), 3/6(+) ■ Mid-span: 4/5(+), 7/8(-) 		
PoE PD Type	<ul style="list-style-type: none"> ■ Standard ■ Legacy ■ Force 		
PoE Power Budget	400 watts	600 watts	800 watts
Number of 95W 802.3bt Type-4 PDs	4	6	8
Number of 60W 802.3bt Type-3 PDs	6	10	13
Number of 802.3at PDs	8	16	22
PoE Management	<ul style="list-style-type: none"> Power limit by consumption and classification PoE function enable/disable Per port PoE function enable/disable Per port PoE power schedule Power feeding priority PD alive check PD classification detection Current per port usage and status Total power consumption 		
Security			
Firewall	SPI Firewall Protection		
Authentication	Authentication Method Configuration		
Filtering	MAC Filtering		
Access Management	HTTP/HTTPS/SNMP		
Certificates	System CA Certificate for HTTPS		
Management Functions			
Management Interface	HTTP/HTTPS Web user interface		
Secure Management Interface	TLSv1.2, TLSv1.3		
Management Feature	<ul style="list-style-type: none"> IPv4 and IPv6 dual stack management Web interface for remote management LLDP Link Layer Discovery Protocol (LLDP) PLANET DDNS and Easy DDNS Supports Network Time Protocol (NTP) System Maintenance <ul style="list-style-type: none"> - Firmware upload via HTTP - Configuration upload/download via HTTP - Reboot button for system reboot - Reset button for system reset to factory default PLANET Smart Discovery utility automatically finds PLANET devices on the network PLANET NMS system and CloudNMS for deployment management 		

	<p>Remote RADIUS Server authentication</p> <p>Scheduled System Power Rebooting</p> <p>Network Diagnostic</p> <ul style="list-style-type: none"> - ICMPv6/ICMPv4 Remote Ping - Trace Route
SNMP Management	<p>SNMP v1, v2c and v3 for system status monitoring</p> <p>SNMP trap for alarm notification of events</p>
Event Management	<p>Local system event log</p> <p>Remote syslog</p>
Standards Conformance	
Regulatory Compliance	FCC Part 15 Class A, CE
Standards Compliance	<p>IEEE 802.3 10BASE-T Ethernet</p> <p>IEEE 802.3u 100BASE-TX Fast Ethernet</p> <p>IEEE 802.3ab 1000BASE-T Gigabit Ethernet</p> <p>IEEE 802.3bz Gigabit 2.5G, 5GBASE-T Ethernet</p> <p>IEEE 802.3an Gigabit 10GBASE-T Ethernet</p> <p>IEEE 802.3af Power over Ethernet</p> <p>IEEE 802.3at Power over Ethernet Plus</p> <p>IEEE 802.3bt Power over Ethernet Plus Plus</p> <p>RFC 768: UDP</p> <p>RFC 791: IP</p> <p>RFC 2068 HTTP</p> <p>RFC 1157: SNMP v1</p> <p>RFC 1902: SNMP v2c</p> <p>RFC 2273: SNMPv3</p> <p>RFC 5424: Syslog</p>
Environments	
Operating	<p>Temperature: 0 ~ 50 degrees C</p> <p>Relative Humidity: 5 ~ 90% (non-condensing)</p>
Storage	<p>Temperature: -10 ~ 70 degrees C</p> <p>Relative Humidity: 5 ~ 90% (non-condensing)</p>

2. INSTALLATION

This section describes the hardware features and installation of 10Gbps 802.3bt PoE++ Managed Injector Hub on the desktop or rack mount. For easier management and control of the 10Gbps 802.3bt PoE++ Managed Injector Hub, familiarize yourself with its display indicators, and ports. Front panel illustrations in this chapter display the unit LED indicators. Before deploying the 10Gbps 802.3bt PoE++ Managed Injector Hub, please read this chapter completely.

2.1 Hardware Description

The section describes the hardware of the 10Gbps 802.3bt PoE++ Managed Injector Hub and gives a physical and functional overview.

2.1.1 Injector Front Panel

The unit front panel provides a simple interface monitoring the 10Gbps 802.3bt PoE++ Managed Injector Hub. [Figures 2-1-1](#), [2-1-2](#) and [2-1-3](#) show the front panels of the 10Gbps 802.3bt PoE++ Managed Injector Hubs.

■ Front Panel of UPOE-800XG



Figure 2-1-1: UPOE-800XG Front Panel

■ Front Panel of UPOE-1600XG



Figure 2-1-2: UPOE-1600XG Front Panel

■ Front Panel of UPOE-2400XG

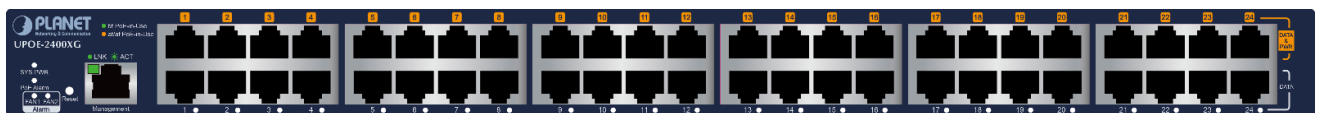

Figure 2-1-3: UPOE-2400XG Front Panel

■ **Reset button**

At the left of the front panel, the reset button is designed for rebooting the 10Gbps 802.3bt PoE++ Managed Injector Hub without turning off and on the power.

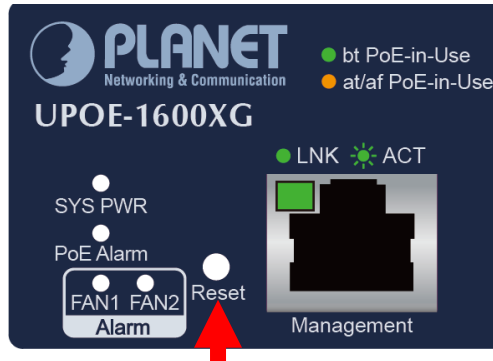

Figure 2-1-4: Reset Button of 10Gbps 802.3bt PoE++ Managed Injector Hub

The following is the summary table of reset button functions:

Reset Button Pressed and Released	Function
About 5 second	Reboot the 10Gbps 802.3bt PoE++ Managed Injector Hub.
About 10 seconds	Reset the 10Gbps 802.3bt PoE++ Managed Injector Hub to Factory Default configuration. The 10Gbps 802.3bt PoE++ Managed Injector Hub will reboot and load the default IP settings.



Be sure that you back up the current configuration of 10Gbps 802.3bt PoE++ Managed Injector Hub before resetting 10Gbps 802.3bt PoE++ Managed Injector Hub or else the entire configuration will be erased when pressing the **“RESET”** button.

2.1.2 LED Indicators

The front panel LEDs indicates instant status of system power, PoE and fan failure, management Link/Active, PoE power usage status and per PoE port links status, thus helping administrator to monitor and troubleshoot when needed.

UPOE-800XG



■ System

LED	Color	Function
SYS Power	Green	Lights to indicate power on.
PoE Alarm	Red	Lights to indicate PoE module failure.
Fan1 Alarm	Red	Lights to indicate Fan 1 has stopped.
Fan2 Alarm	Red	Lights to indicate Fan 2 has stopped.
Management Port	Green	Lights to indicate the link through that port is successfully established at 10100/1000Mbps.

■ Per 10/100/1000/2.5G/5G/10GBASE-T 802.3bt PoE++ Port (Port 1 to Port 8)

LED	Color	Function
bt PoE-in-use	Green	Lights to indicate that the port is in use and supplying bt PoE++ in-line power.
802.3at/af PoE-in-Use	Amber	Lights to indicate that the port is in use and supplying af/at PoE+ in-line power.

UPOE-1600XG

■ System

LED	Color	Function
SYS Power	Green	Lights to indicate power on.
PoE Alarm	Red	Lights to indicate PoE module failure.
Fan1 Alarm	Red	Lights to indicate Fan 1 has stopped.
Fan2 Alarm	Red	Lights to indicate Fan 2 has stopped.
Management Port	Green	Lights to indicate the link through that port is successfully established at 10100/100Mbps.

■ Per 10/100/1000/2.5G/5G/10GBASE-T 802.3bt PoE++ Port (Port 1 to Port 16)

LED	Color	Function
bt PoE-in-use	Green	Lights to indicate that the port is in use and supplying bt PoE++ in-line power.
802.3at/af PoE-in-Use	Amber	Lights to indicate that the port is in use and supplying af/at PoE+ in-line power.

UPOE-2400XG

■ System

LED	Color	Function
SYS Power	Green	Lights to indicate power on.
PoE Alarm	Red	Lights to indicate PoE module failure.
Fan1 Alarm	Red	Lights to indicate Fan 1 has stopped.
Fan2 Alarm	Red	Lights to indicate Fan 2 has stopped.
Management Port	Green	Lights to indicate the link through that port is successfully established at 10/100/1000Mbps.

■ Per 10/100/1000/2.5G/5G/10GBASE-T 802.3bt PoE++ Port (Port 1 to Port 24)

LED	Color	Function
bt PoE-in-use	Green	Lights to indicate that the port is in use and supplying bt PoE++ in-line power.
802.3at/af PoE-in-Use	Amber	Lights to indicate that the port is in use and supplying af/at PoE+ in-line power.

2.1.3 Injector Rear Panel

The rear panel of the 10Gbps 802.3bt PoE++ Managed Injector Hub indicates an AC inlet power socket, which accepts input power from 100 to 240V AC, 50/60Hz. [Figures 2-1-5 & 2-1-6 & 2-1-7](#) shows the rear panel of the 10Gbps 802.3bt PoE++ Managed Injector Hub.



Figure 2-1-5: UPOE-800XG Rear Panel



Figure 2-1-6: UPOE-1600XG Rear Panel



Figure 2-1-7: UPOE-2400XG Rear Panel



The 10Gbps 802.3bt PoE++ Managed Injector Hub is a power-required device, meaning 10Gbps 802.3bt PoE++ Managed Injector Hub will not work till it is powered. If your networks should be active all the time, please consider using UPS (Uninterrupted Power Supply) for your device. It will prevent you from network data loss or network downtime.



In some areas, installing a surge suppression device may also help to protect your device from being damaged by unregulated surge or current to the 10Gbps 802.3bt PoE++ Managed Injector Hub or the power adapter.

2.2 Installing the 10Gbps 802.3bt PoE++ Managed Injector Hub

This section describes how to install your 10Gbps 802.3bt PoE++ Managed Injector Hub and make connections to the 10Gbps 802.3bt PoE++ Managed Injector Hub. Please read the following topics and perform the procedures in the order being presented. PLANET 10Gbps 802.3bt PoE++ Managed Injector Hub does not need software configuration.

2.2.1 Desktop Installation

To install an 10Gbps 802.3bt PoE++ Managed Injector Hub on a desktop or shelf, simply complete the following steps:

Step 1: Attach the rubber feet to the recessed areas on the bottom of the 10Gbps 802.3bt PoE++ Managed Injector Hub.

Step 2: Place the 10Gbps 802.3bt PoE++ Managed Injector Hub on a desktop or shelf near an AC power source.

Step 3: Keep enough ventilation space between the 10Gbps 802.3bt PoE++ Managed Injector Hub and the surrounding objects.

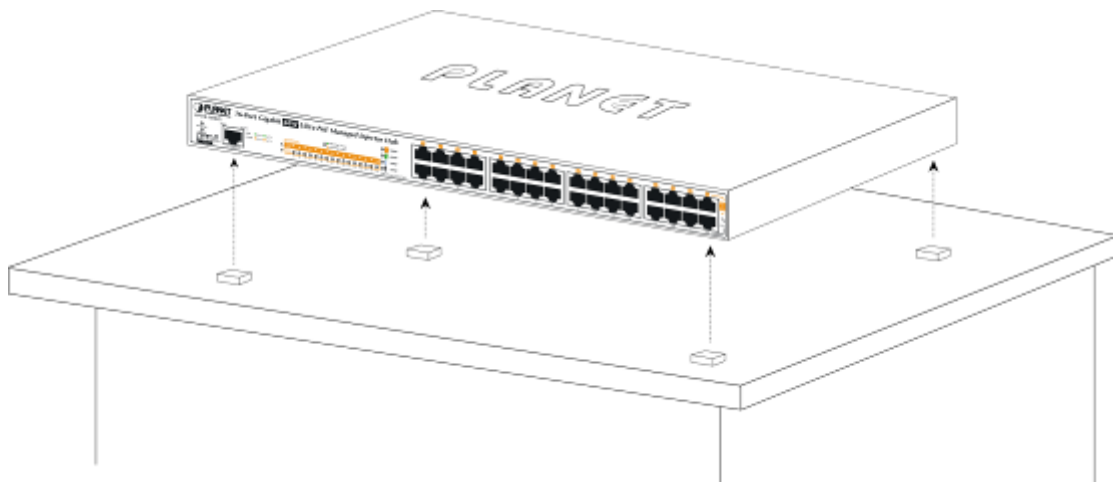

Figure 2-2-1: Desktop Installation of the 10Gbps 802.3bt PoE++ Managed Injector Hub



When choosing a location, please keep in mind the environmental restrictions discussed in Chapter 1, Section 5, under Specifications.

Step 4: Connect your 10Gbps 802.3bt PoE++ Managed Injector Hub to 802.3at/802.3af/802.3bt powered devices (PD) and Switch.

- A. Connect one end of a standard network cable to the upper stack 10/100/1000/2.5G/5G/10GBASE-T RJ45 ports on the front of the 10Gbps 802.3bt PoE++ Managed Injector Hub.
- B. Connect the other end of the cable to the 802.3at/802.3af/802.3bt powered devices (PD) such as IP phone, wireless access point, IP camera, splitter, or switch etc.
- C. Connect one end of a standard network cable to the relative lower stack 10/100/1000/2.5G/5G/10GBASE-T RJ45 ports on the front of the 10Gbps 802.3bt PoE++ Managed Injector Hub.
- D. Connect the other end of the cable to the port of Switch.



Connecting to the 10Gbps 802.3bt PoE++ Managed Injector Hub requires UTP Category 5/5e/6/7 network cabling with RJ45 tips. For more information, please see the Cabling Specification in Appendix A.

Step 5: Supplying Power to the 10Gbps 802.3bt PoE++ Managed Injector Hub.

- A. Connect one end of the power cable to the 10Gbps 802.3bt PoE++ Managed Injector Hub.
- B. Connect the power plug of the power cable to a standard wall outlet.

When the 10Gbps 802.3bt PoE++ Managed Injector Hub receives power, the Power LED should remain solid Green.

2.2.2 Rack Mounting

To install the 10Gbps 802.3bt PoE++ Managed Injector Hub in a 19-inch standard rack, follow the instructions described below.

Step 1: Place your 10Gbps 802.3bt PoE++ Managed Injector Hub on a hard flat surface, with the front panel positioned towards your front side.

Step 2: Attach a rack-mount bracket to each side of the 10Gbps 802.3bt PoE++ Managed Injector Hub with supplied screws attached to the package. [Figure 2-2-2](#) shows how to attach brackets to one side of the 10Gbps 802.3bt PoE++ Managed Injector Hub.

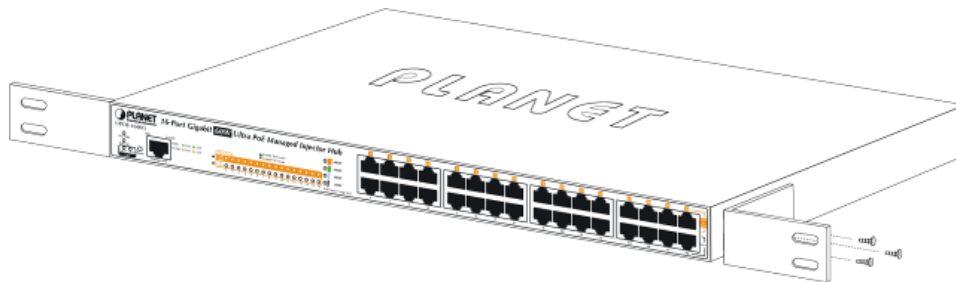

Figure 2-2-2: Brackets attaching to the 10Gbps 802.3bt PoE++ Managed Injector Hub



You must use the screws supplied with the mounting brackets. Damage caused to the parts by using incorrect screws would invalidate the warranty.

Step 3: Secure the brackets tightly.

Step 4: Follow the same steps to attach the second bracket to the opposite side.

Step 5: After the brackets are attached to the Injector, use suitable screws to securely attach the brackets to the rack, as shown in [Figure 2-2-3](#).

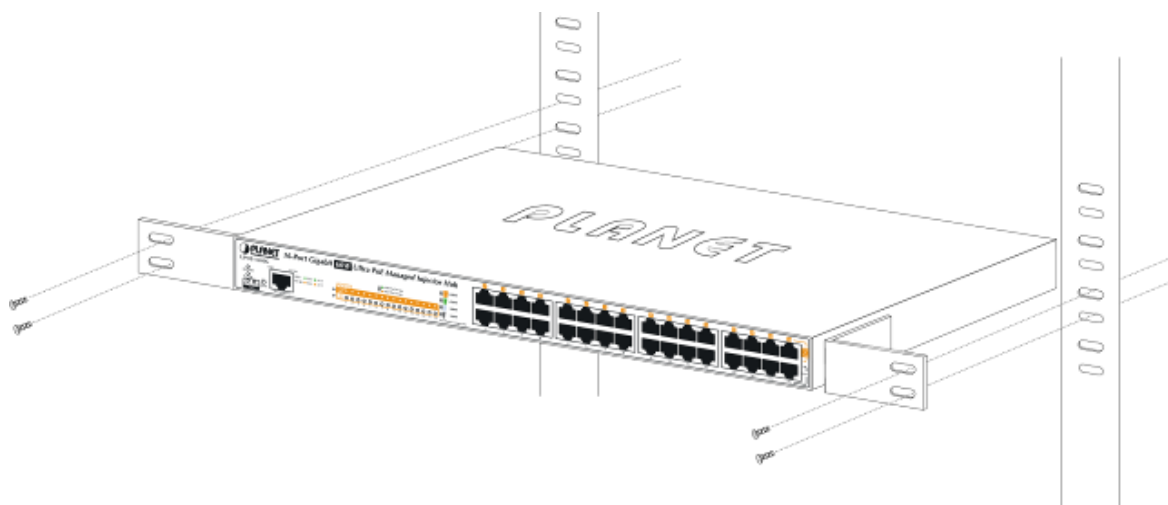

Figure 2-2-3: Mounting the 10Gbps 802.3bt PoE++ Managed Injector Hub in a Rack

Step 6: Proceed with steps 4 and 5 under section **2.2.1 Desktop Installation** to connect the network cabling and supply power to your 10Gbps 802.3bt PoE++ Managed Injector Hub.

2.2.3 Network Application Installation

The 10Gbps 802.3bt PoE++ Managed Injector Hub is not an equipment with data switching function between data ports. To inject PoE power and transmit data packets to PDs, the 10Gbps 802.3bt PoE++ Managed Injector Hub is usually linked to an Ethernet switch. Typically, the Ultra PoE Injector is installed between regular Ethernet switch and PDs, and mostly it is located close to the Ethernet switch side.

To install an 10Gbps 802.3bt PoE++ Managed Injector Hub on a network environment, simply complete the following steps:

Step 1: Power on the 10Gbps 802.3bt PoE++ Managed Injector Hub and connect the RJ45 cable from the “Data” port to the Ethernet switch port.

Step 2: Connect the RJ45 cable from the “Data + Power” ports to the PDs, such as VoIP phone and IP camera.

Step 3: Check the link status on both PD and Ethernet switch. Once the Injector starts to deliver 54V power over RJ45 cables to PDs, the PoE-in-Use LED of the 10Gbps 802.3bt PoE++ Managed Injector Hub will light up.

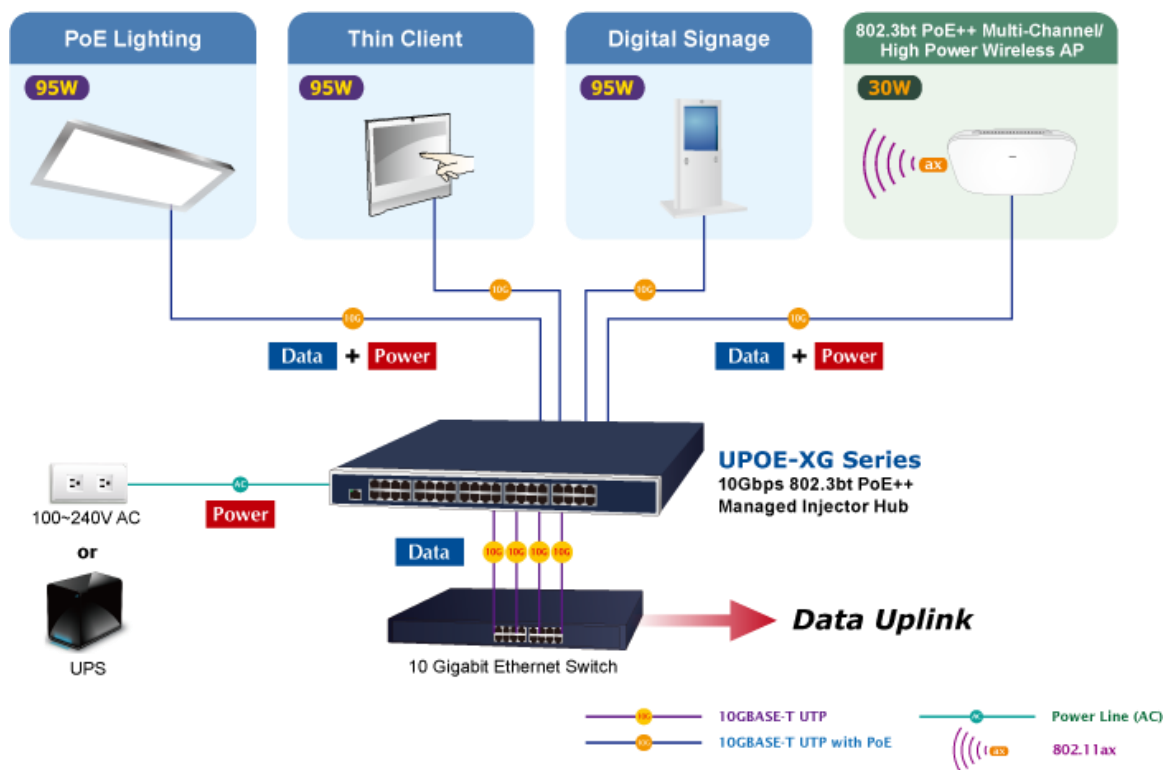







Figure 2-2-4: Network application installation

The 10Gbps 802.3bt PoE++ Managed Injector Hub supports data passive mode, that is, even the 10Gbps 802.3bt PoE++ Managed Injector Hub is manually powered off. The data between “DATA” port and “DATA & PWR” port can still be transmitted without data loss.

2.2.4 Power over Ethernet Powered Device

 <p>3~5 watts</p>	<p>Voice over IP phones Enterprise can install PoE VoIP Phone, ATA and other Ethernet/non-Ethernet end-devices in the central area where UPS is installed for un-interruptible power system and power control system.</p>
 <p>6~12 watts</p>	<p>Wireless LAN Access Points Museums, sightseeing spots, airports, hotels, campuses, factories, and warehouses can be installed with Access Points anywhere.</p>
 <p>10~12 watts</p>	<p>IP Surveillance Enterprises, museums, campuses, hospitals and banks can be installed with IP cameras without the limit of the installation location. Electrician is not needed to install AC sockets.</p>
 <p>3~60 watts</p>	<p>PoE Splitter PoE Splitter splits the PoE DC over the Ethernet cable into 5/12/19/24V DC power output. It frees the device deployment from restrictions due to power outlet locations, which eliminate the costs for additional AC wiring and reduces the installation time.</p>
 <p>30~60 watts</p>	<p>High Power Speed Dome This state-of-the-art design is considerable to fit in various network environments like traffic centers, shopping malls, railway stations, warehouses, airports, and production facilities for the most demanding outdoor surveillance applications. Electrician is not needed to install AC sockets.</p>



Since each PoE port of 10Gbps 802.3bt PoE++ Managed Injector Hub supports **54V DC (UPOE-800XG/ UPOE-1600XG/UPOE-2400XG)** PoE power output, be sure that the powered device's acceptable DC power is **54V DC (UPOE-800XG/UPOE-1600XG/UPOE-2400XG)**; otherwise, it will damage the PD.

3. MANAGEMENT

This chapter describes how to manage the 10Gbps 802.3bt PoE++ Managed Injector Hub with the following sections included:

- Overview
- Management Method
- Logging on to the 10Gbps 802.3bt PoE++ Managed Injector Hub

3.1 Overview

The 10Gbps 802.3bt PoE++ Managed Injector Hub provides a user-friendly, Web interface where you can perform various device configuration and management activities, including:

- System
- SNMP
- Power over Ethernet

3.2 Requirements

- Network cables
Use standard network (UTP) cables with RJ45 connectors.
- Workstations running Windows 2003/2008/2012/7/8/10/11, MAC OS X or later, Linux, UNIX, or other platforms are compatible with TCP/IP protocols.
- Workstations are installed with Ethernet NIC (Network Interface Card)

Ethernet Port Connection

- Workstations are installed with Ethernet NIC (Network Interface Card)
- Network cables -- Use standard network (UTP) cables with RJ45 connectors.
- The above PC is installed with Web browser.



It is recommended to use Chrome 98.0.xxx or above to access the 10Gbps 802.3bt PoE++ Managed Injector Hub. If the Web interface of the 10Gbps 802.3bt PoE++ Managed Injector Hub is not accessible, please turn off the anti-virus software or firewall and then try it again.

3.3 Management Method

User can manage the 10Gbps 802.3bt PoE++ Managed Injector Hub by Web Management via a network connection.

3.3.1 Web Management

The 10Gbps 802.3bt PoE++ Managed Injector Hub can be configured through an Ethernet connection. The factory default IP address is **192.168.0.100** with subnet mask **255.255.255.0**, so please make sure the manager PC must be set to the same **IP subnet address**. For example, if 10Gbps 802.3bt PoE++ Managed Injector Hub IP address is set to factory default, then your manager PC should be set to **192.168.0.x** (where x is a number between 1 and 254, except 100) with a subnet mask of **255.255.255.0**.



The following web screen is based on the UPOE-1600XG. The displays of the UPOE-800XG and UPOE-2400XG are the same as that of the UPOE-1600XG.

1. Use Chrome 98.0.xxx or above Web browser. Enter IP address **https://192.168.0.100** to access the Web interface.

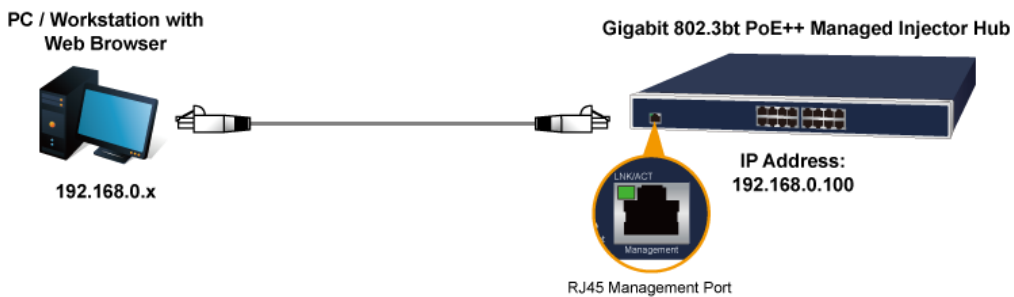

Figure 3-1-1: IP Management Diagram

2. When the following dialog box appears, please enter the default user name "**admin**" and the password that is initially logged in to.

Default IP Address: **192.168.0.100**
 Default User Name: **admin**
 Default Password: **sw + the last 6 characters of the MAC ID in lowercase**

5. Enter the default username and password, then set a new password according to the rule-based prompt and confirm it. Upon success, press any key to return to the login prompt. Log in with "admin" and the "new password" to access the Web interface.



Figure 3-1-5: Web Main Screen of 10Gbps 802.3bt PoE++ Managed Injector Hub



1. For security reason, please change and memorize the new password after this first setup.
2. Only accept command in lowercase letter under Web interface.

3.3.2 PLANET Smart Discovery Utility

For easily listing the 10Gbps 802.3bt PoE++ Managed Injector Hub in your Ethernet environment, the search tool -- PLANET Smart Discovery Utility -- is an ideal solution.

The following installation instructions are to guide you to running the PLANET Smart Discovery Utility.

Download the PLANET Smart Discovery Utility in administrator PC.

Run this utility as the following screen appears.

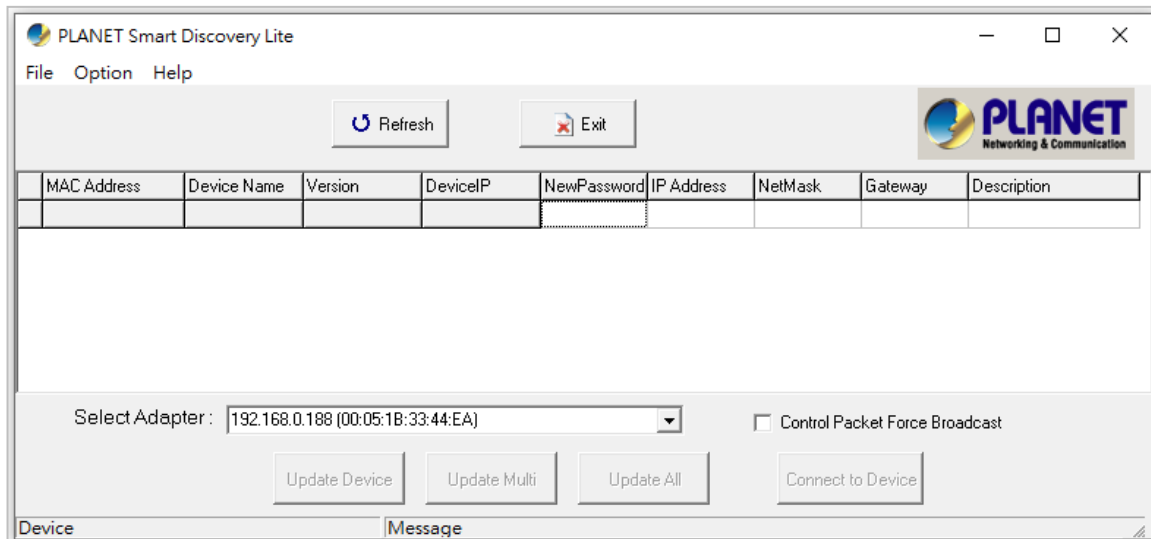

Figure 3-1-6: PLANET Smart Discovery Utility Screen



If there are two LAN cards or above in the same administrator PC, choose a different LAN card by using the “**Select Adapter**” tool.

1. Press the “**Refresh**” button for the currently-connected devices in the discovery list and the screen is shown as follows:

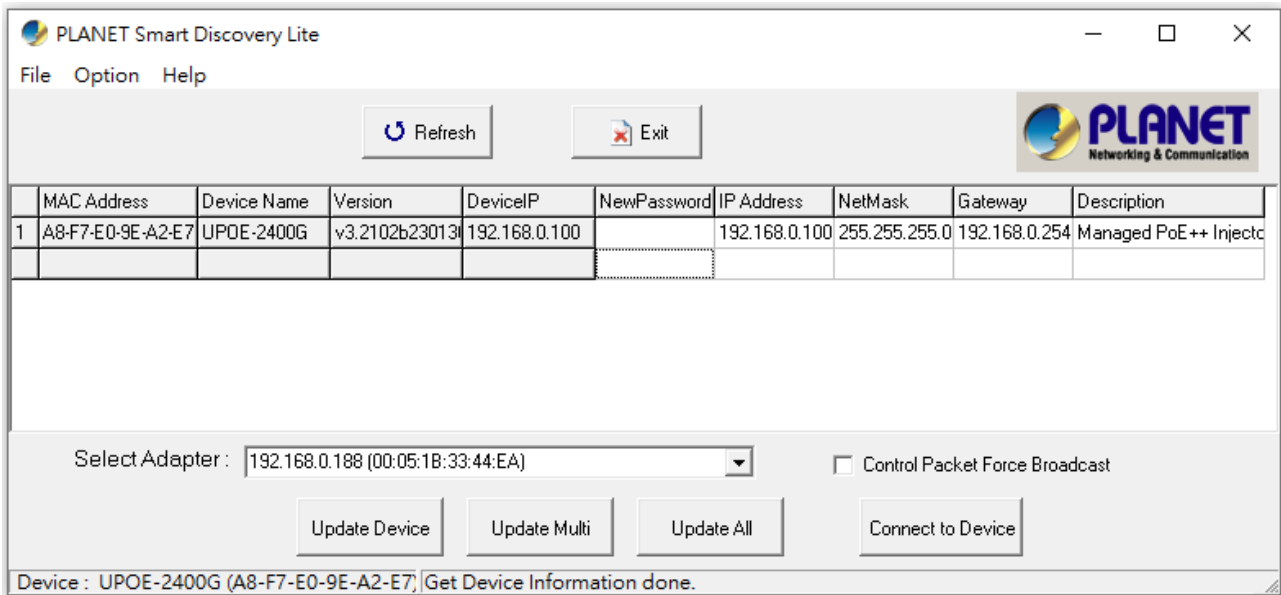

Figure 3-1-7: PLANET Smart Discovery Utility Screen

This utility shows all necessary information from the devices, such as MAC address, device name, firmware version and device IP subnet address. It can also assign new password, IP subnet address and description of the devices. After setup is completed, press the “**Update Device**”, “**Update Multi**” or “**Update All**” button to take effect. The definitions of the 3 buttons above are shown below:

Update Device: Use current setting on one single device.

Update Multi: Use current setting on multi-devices.

Update All: Use current setting on whole devices in the list.

The same functions mentioned above also can be found in “**Option**” tools bar.

By clicking the “**Control Packet Force Broadcast**” function, it allows you to assign new setting value to the 10Gbps 802.3bt PoE++ Managed Injector Hub under a different IP subnet address.

Press the “**Connect to Device**” button and then the Web login screen appears in [Figure 3-1-3](#).

Press the “**Exit**” button to shut down PLANET Smart Discovery Utility.

4 WEB CONFIGURATION

The 10Gbps 802.3bt PoE++ Managed Injector Hub provides Web interface for PoE smart function configuration and makes the 10Gbps 802.3bt PoE++ Managed Injector Hub operate more effectively. They can be configured through the Web browser. A network administrator can manage and monitor the 10Gbps 802.3bt PoE++ Managed Injector Hub from the local LAN. This section indicates how to configure the 10Gbps 802.3bt PoE++ Managed Injector Hub to enable its smart function.



The following web screen is based on the UPOE-1600XG. The displays of the UPOE-800XG and UPOE-2400XG are the same as that of the UPOE-1600XG.

4.1 Main Menu

After a successful login, the main screen appears. The main screen, as shown in [Figure 4-1-1](#), displays the product name, the function menu, and the main information in the center.

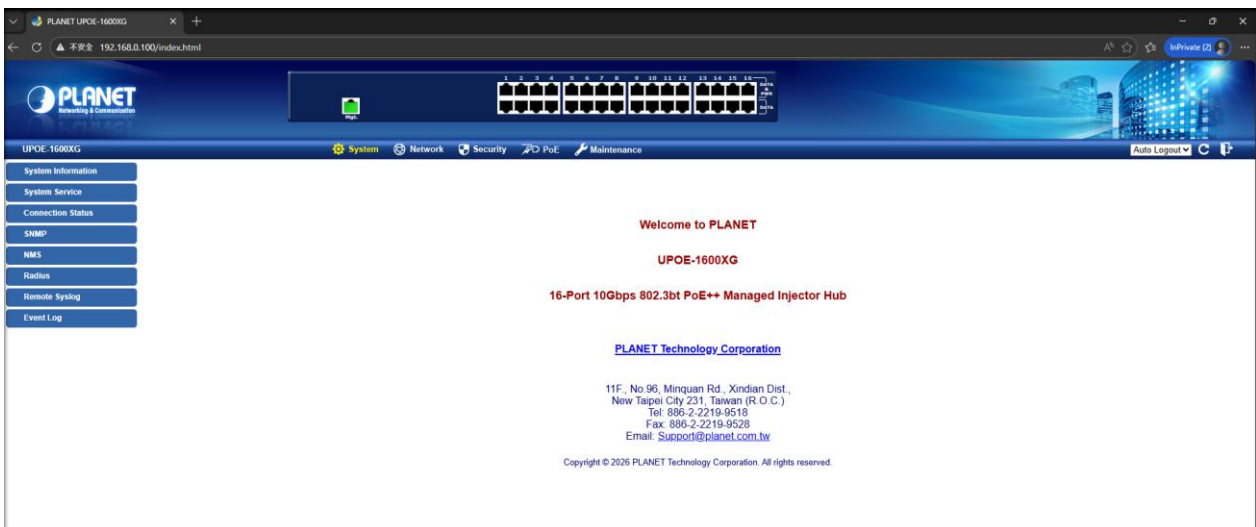

Figure 4-1-1: Web Main Menu screen

■ Main Menu

The main menu displays the product name, function menu, and main information in the center. Via the Web management, the administrator can set up the device by selecting the functions those listed in the function menu and button as shown in Figures 4-1-2 and 4-1-3.



Figure 4-1-2: Function Menu

Main Menu	
Object	Description
System	Provides system information of the 10Gbps 802.3bt PoE++ Managed Injector Hub .
Network	Provides LAN and network configuration of the 10Gbps 802.3bt PoE++ Managed Injector Hub .
Security	Provides firewall and security configuration of the 10Gbps 802.3bt PoE++ Managed Injector Hub .
PoE	Provides PoE Management configuration of the 10Gbps 802.3bt PoE++ Managed Injector Hub .
Maintenance	Provides firmware upgrade and setting file restore/backup configuration of the 10Gbps 802.3bt PoE++ Managed Injector Hub .

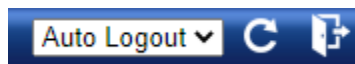



Figure 4-1-3: Function Button

Auto Logout	
Object	Description
<div style="border: 1px solid black; padding: 2px;"> Auto Logout ▾ Auto Logout Off 3 min 5 min 10 min 15 min </div>	Provide various Web Logout time options, the available options are shown as below: Auto Logout (Default mode) Off 3 min 5 min 10 min 15 min
	Click the " Refresh button " to refresh the current web page.
	Click the " Logout button " to log out the web UI of the 10Gbps 802.3bt PoE++ Managed Injector Hub .

4.2 System

Use the system menu items to display and configure basic administrative details of the 10Gbps 802.3bt PoE++ Managed Injector Hub. The System menu shown in [Figure 4-2-1](#) provides the following features to configure and monitor system.

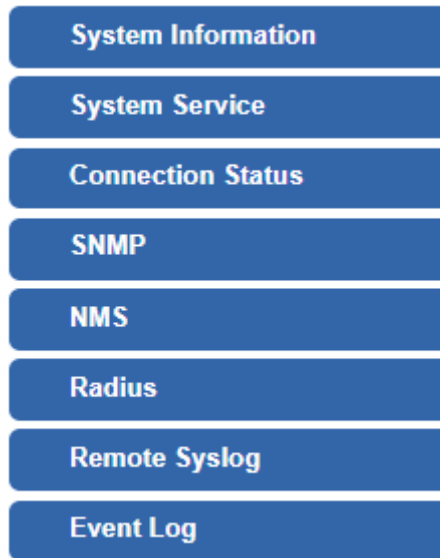

Figure 4-2-1: System Menu

The page includes the following information:

System	
Object	Description
System Information	Display the status of the Device Information and LAN Information.
System Service	Display the status of the Service and Secured Service information.
Connection Status	Display the ARP table information.
SNMP	Display SNMP system information.
NMS	Enable/Disable NMS on 10Gbps 802.3bt PoE++ Managed Injector Hub.
Radius	Configure the Radius function of 10Gbps 802.3bt PoE++ Managed Injector Hub.
Remote Syslog	Enable Remote syslog on 10Gbps 802.3bt PoE++ Managed Injector Hub.
Event Log	Display Event Log information on 10Gbps 802.3bt PoE++ Managed Injector Hub.

4.2.1 System Information

This section displays system information of 10Gbps 802.3bt PoE++ Managed Injector Hub as the screen in [Figure 4-2-2](#) appears. [Table 4-2-1](#) & [4-2-2](#) describes the system information of the 10Gbps 802.3bt PoE++ Managed Injector Hub.

Device Information	
Model Name	UPOE-1600XG
Hardware Version	v1.0
Firmware Version	v1.2102b260212
Serial Number	AF007626300001
Current Time	2021-04-22 Thursday 21:47:09
Running Time	0 day, 05:35:46
Fan Status	Low

LAN	
MAC Address	A8:F7:E0:FC:A3:9E
Connection Type	Static
IP Address	192.168.0.100
Netmask	255.255.255.0
Gateway	192.168.0.254

Figure 4-2-2: System Information Web Page Screen

Device Information	
Object	Description
• Model Name	Displays the 10Gbps 802.3bt PoE++ Managed Injector Hub model name.
• Hardware Version	Displays the 10Gbps 802.3bt PoE++ Managed Injector Hub hardware version.
• Firmware Version	Displays the 10Gbps 802.3bt PoE++ Managed Injector Hub firmware version.
• Serial Number	Displays the 10Gbps 802.3bt PoE++ Managed Injector Hub serial number.
• Current Time	Display the 10Gbps 802.3bt PoE++ Managed Injector Hub current time information.
• Running Time	Display the 10Gbps 802.3bt PoE++ Managed Injector Hub operation time information.
• Fan Status	Display the 10Gbps 802.3bt PoE++ Managed Injector Hub current fan operation speed status information.



Table 4-2-1: Descriptions of the Device Information Objects Screen

LAN	
Object	Description
• MAC Address	Displays the 10Gbps 802.3bt PoE++ Managed Injector Hub MAC address.
• Connection Type	Displays the 10Gbps 802.3bt PoE++ Managed Injector Hub current IP connection type information.
• IP Address	Displays the 10Gbps 802.3bt PoE++ Managed Injector Hub current IP address.
• Netmask	Displays the 10Gbps 802.3bt PoE++ Managed Injector Hub current subnet mask address.
• Gateway	Displays the 10Gbps 802.3bt PoE++ Managed Injector Hub current gateway address.

Table 4-2-2: Descriptions of the LAN Objects Screen

4.2.2 System Service

This section displays the system service status of the 10Gbps 802.3bt PoE++ Managed Injector Hub, the system service are shown in Figure 4-2-3 appears. Table 4-2-3 & 4-2-4 describes the system service object of 10Gbps 802.3bt PoE++ Managed Injector Hub.

Service			
#	State	Service	Detail
1	 Disabled	DDNS Service	Not enabled
2	 Disabled	SNMP Service	



Secured Service			
#	State	Service	Detail
1	 Enabled	Cybersecurity	TLS 1.2, TLS 1.3
2	 Enabled	SPI Firewall	
3	 Disabled	MAC Filtering	(Active / Maximum Entries) 0 / undefined

Figure 4-2-3: System Service Web Page Screen

Service	
Object	Description
• State	Displays the 10Gbps 802.3bt PoE++ Managed Injector Hub service state information.
• Service	Displays the 10Gbps 802.3bt PoE++ Managed Injector Hub service type information. DDNS Service and SNMP Service.
• Detail	Displays the 10Gbps 802.3bt PoE++ Managed Injector Hub service detail information.

Table 4-2-3: Descriptions of the Service Objects Screen

Secure Service	
Object	Description
• State	Displays the 10Gbps 802.3bt PoE++ Managed Injector Hub service state information.
• Service	Displays the 10Gbps 802.3bt PoE++ Managed Injector Hub service type information. Cybersecurity/SPI Firewall/MAC Filtering.
• Detail	Displays the 10Gbps 802.3bt PoE++ Managed Injector Hub service detail information.

Table 4-2-4: Descriptions of the Secure Service Objects Screen

4.2.3 Connection Status

This section displays the ARP table of 10Gbps 802.3bt PoE++ Managed Injector Hub as the screen in [Figure 4-2-4](#) appears and [Table 4-2-5](#) describes the ARP table object of 10Gbps 802.3bt PoE++ Managed Injector Hub.

ARP Table		
IP Address	MAC Address	ARP Type
192.168.0.254	00:00:00:00:00:00	unknown
192.168.0.188	00:05:1b:33:44:ea	dynamic

Figure 4-2-4: Connection Status Web Page Screen

ARP Table	
Object	Description
• IP Address	Displays the 10Gbps 802.3bt PoE++ Managed Injector Hub IP Address Information.
• MAC Address	Displays the 10Gbps 802.3bt PoE++ Managed Injector Hub MAC Address information.
• ARP Type	Displays the 10Gbps 802.3bt PoE++ Managed Injector Hub ARP Type information.

Table 4-2-5: Descriptions of the ARP Table Objects Screen

4.2.4 SNMP

This section provides the SNMP Setting of 10Gbps 802.3bt PoE++ Managed Injector Hub as the screen in [Figure 4-2-5](#) appears. [Table 4-2-6](#) & [4-2-7](#) & [4-2-8](#) describes the Password Setting objects of 10Gbps 802.3bt PoE++ Managed Injector Hub .

SNMP

SNMP	<input type="radio"/> Enable <input checked="" type="radio"/> Disable	
SNMP Versions	<input type="text" value="SNMP v1,v2c"/>	
Read Community	<input type="text" value="public"/>	<input checked="" type="radio"/> Enable <input type="radio"/> Disable
Write Community	<input type="text" value="private"/>	<input checked="" type="radio"/> Enable <input type="radio"/> Disable
Engine ID	<input type="text"/>	
SNMP v3 Security Level	<input type="text" value="AuthPriv"/>	
SNMP v3 User Name	<input type="text"/>	
SNMP v3 Auth Protocol	<input type="text" value="MD5"/>	
SNMP v3 Auth Password	<input type="text"/>	
SNMP v3 Privacy Protocol	<input type="text" value="DES"/>	
SNMP v3 Privacy Password	<input type="text"/>	

System Identification

System Name	<input type="text" value="UPOE-1600XG"/>	
System Description	<input type="text" value="Managed PoE++ Injector Hu"/>	
System Location	<input type="text" value="Default Location"/>	
System Contact	<input type="text" value="Default Contact"/>	

SNMP Trap Receiver Configuration

SNMP Trap	<input type="radio"/> Enable <input checked="" type="radio"/> Disable	
SNMP Trap Destination 1	<input type="text"/>	
SNMP Trap Destination 2	<input type="text"/>	

Figure 4-2-5: SNMP Setting Web Page Screen

SNMP	
Object	Description
SNMP	Disable or enable the SNMP function. The default configuration is enabled.
SNMP Versions	Choose specific SNMP version. The default configuration is SNMPv1, v2c.
Read/Write Community	Allows entering characters for SNMP Read/Write Community of the 10Gbps 802.3bt PoE++ Managed Injector Hub .
Engine ID	This function with SNMP v1, v2c.v3.
SNMP v3 Security Level	This function with SNMP v1, v2c.v3, the default configuration is AuthPRiv.
SNMP v3 User Name	This function with SNMP v1, v2c.v3.
SNMP v3 Auth Protocol	This function with SNMP v1, v2c.v3, the default configuration is MD5.
SNMP v3 Auth Password	This function with SNMP v1, v2c.v3.
SNMP v3 Privacy Protocol	This function with SNMP v1, v2c.v3, the default configuration is DES.
SNMP v3 Privacy Password	This function with SNMP v1, v2c.v3.

Table 4-2-6: Descriptions of the SNMP Objects Screen

System Identification	
Object	Description
System Name	Allows entering characters for system name of the 10Gbps 802.3bt PoE++ Managed Injector Hub .
System Description	Allows entering characters for system descrip of the 10Gbps 802.3bt PoE++ Managed Injector Hub .
System Location	Allows entering characters for system location of the 10Gbps 802.3bt PoE++ Managed Injector Hub .
System Contact	Allows entering characters for system contact of the 10Gbps 802.3bt PoE++ Managed Injector Hub .

Table 4-2-7: Descriptions of the SNMP System Identification Objects Screen

SNMP Trap Receiver Configuration	
Object	Description
SNMP Trap	Allows disable or enable SNMP trap function of the 10Gbps 802.3bt PoE++ Managed Injector Hub .
SNMP Trap Destination 1	Allows to send SNMP trap to an assigned workstation.
SNMP Trap Destination 2	Allows to send SNMP trap to an assigned workstation.

Table 4-2-8: Descriptions of the SNMP Trap Receiver Configuration Objects Screen

4.2.5 NMS

The 10Gbps 802.3bt PoE++ Managed Injector Hub supports both NMS controller and CloudNMS Sever for remote management. PLANET's NMS Controller is a Network Management System can monitor all kinds of deployed network devices, such as managed switches, media converters, routers, smart APs, VoIP phones, IP cameras, etc., compliant with the SNMP Protocol, ONVIF Protocol and PLANET Smart Discovery utility. The CloudNMS is a free networking service just for PLANET Products. This service provides simplified network monitoring and real-time network status. Working with PLANET CloudNMS app, user can easily check network status, device information, Port and PoE status from Internet. Any other services are not included.

This section provides NMS Controller and CloudNMS Server – Internet screens – is shown in [Figure 4-2-6](#). [Table 4-2-9](#) describes the NMS Setting objects of 10Gbps 802.3bt PoE++ Managed Injector Hub.

The **NMS Controller** – LAN Configuration screens in below appear.

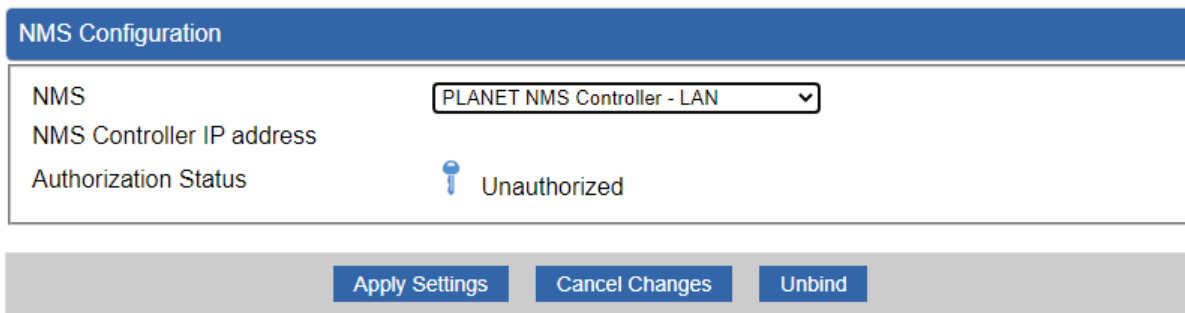

Figure 4-2-6: NMS Configuration Web Page Screen

Object	Description
• NMS	Enable NMS Controller management.
• NMS Controller IP address	The IP address of NMS Controller.
• Authorization Status	Indicate the authorization status of the switch to NMS Controller.

Table 4-2-9: Descriptions of the NMS Configuration Objects Screen

The **CloudNMS** Server – Internet screen in below appears.

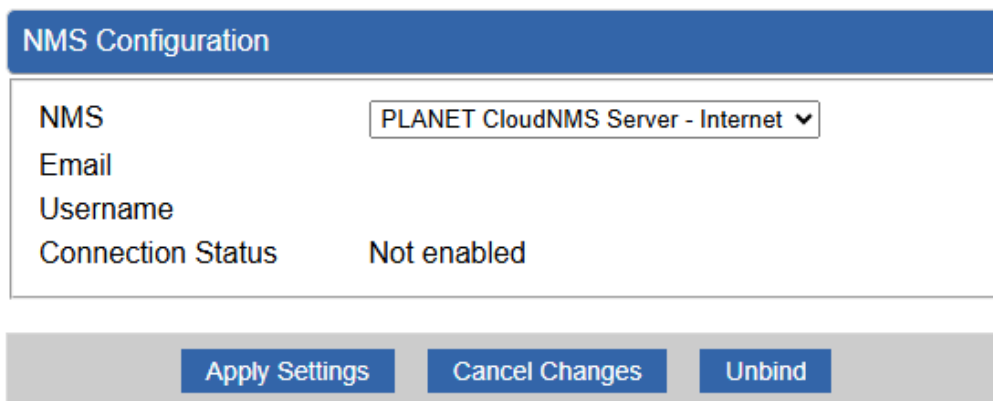

Figure 4-2-6: NMS Configuration Web Page Screen

NMS Configuration	
Object	Description
NMS	Enable PLANET CloudNMS Server management.
Email	The email is registered on CloudNMS Server.
Username	The username of your CloudNMS account.
Connection Status	Indicates the status of connecting CloudNMS Server.

Table 4-2-9: Descriptions of the NMS Configuration Objects Screen

The following section describes the step-by-step process for connecting the 10Gbps 802.3bt PoE++ Managed Injector Hub to PLANET CloudNMS, following the configuration in Section 4.2.16.

The 10Gbps 802.3bt PoE++ Managed Injector Hub can connect to the PLANET CloudNMS Server – Internet for centralized remote management.

CloudNMS is PLANET’s cloud-based network management platform that allows administrators to monitor, configure, and control PLANET devices anytime and anywhere through a web portal or mobile app.

Once registered and connected, users can remotely monitor device status, manage firmware, and receive instant alerts for event notifications.

Step 1: Enable the Service

Go to the NMS Configuration page of the 10Gbps 802.3bt PoE++ Managed Injector Hub and enable PLANET CloudNMS Server – Internet feature.

NMS Configuration

NMS	PLANET CloudNMS Server - Internet ▼
Email	
Username	
Connection Status	Not enabled

Apply Settings
Cancel Changes
Unbind

Step 2: Access the CloudNMS Platform

Open a browser and go to <https://www.cloudnms.planet.com.tw>,
or download the PLANET CloudNMS App from the App Store or Google Play.

Web:

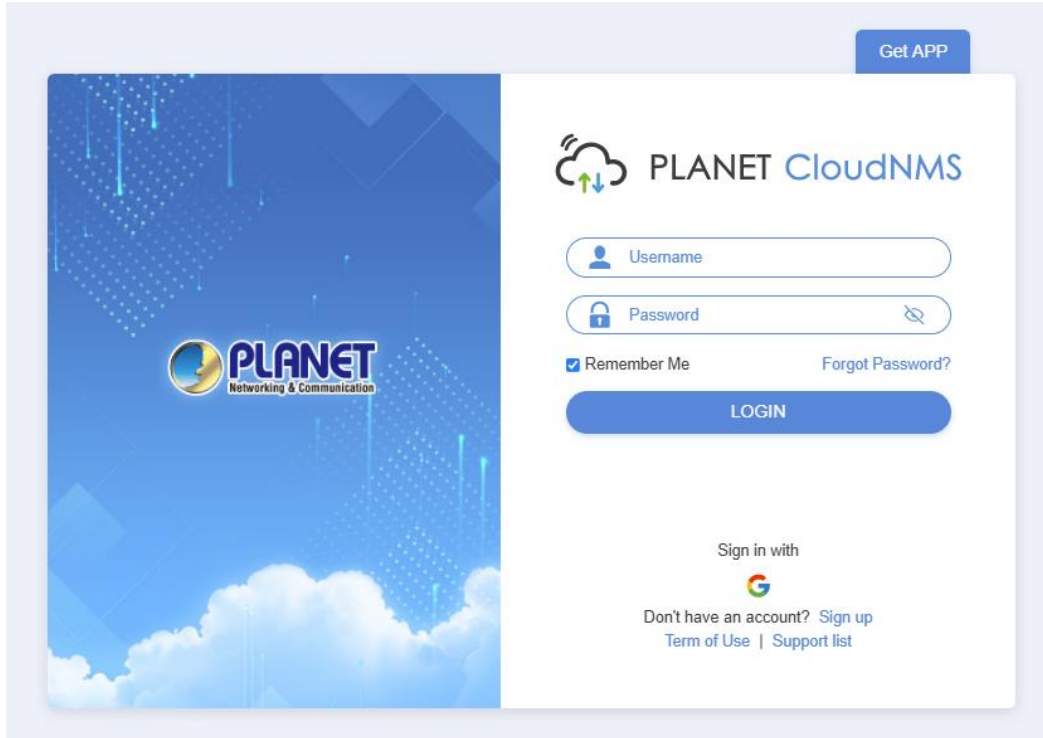

App:



Step 3: Register an Account

Launch the PLANET CloudNMS Platform or App, and log in with your CloudNMS account.

If you don't have an account, register one with your e-mail address first, or use SSO.

Web:

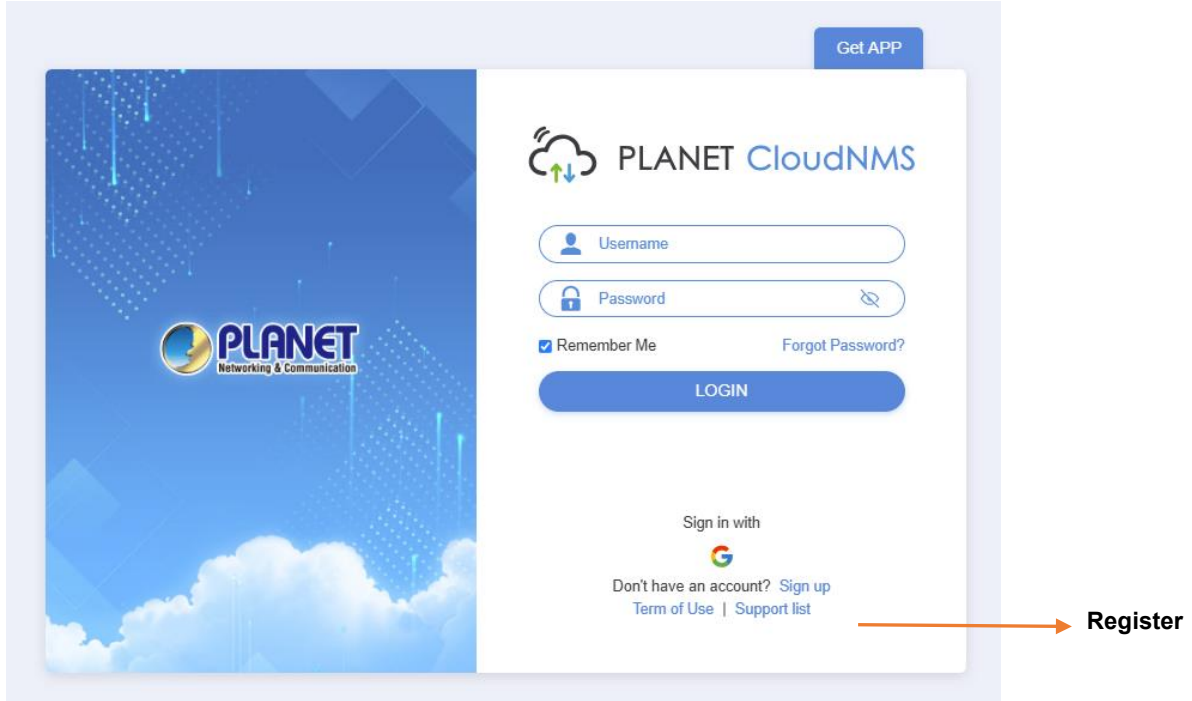

App:

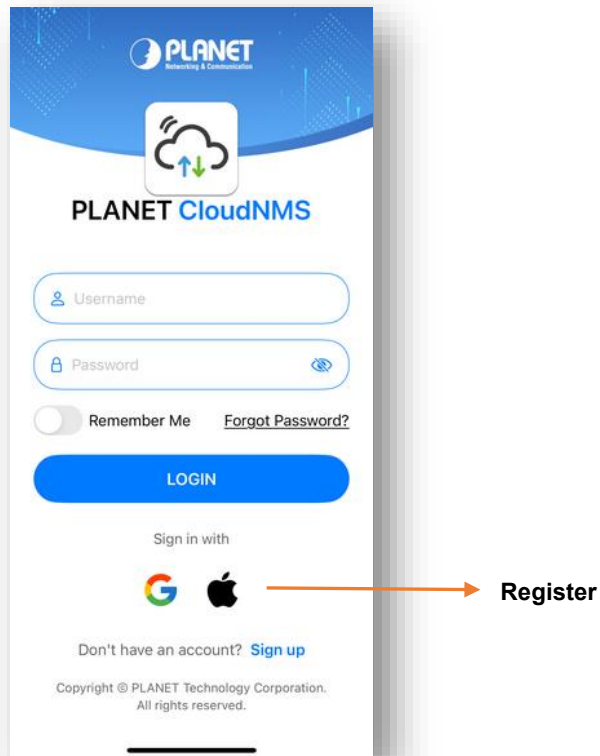

Step 4: Bind the Device

Via Web:

- Log in to the PLANET CloudNMS Platform.
- Create an Organization and a Network for the device.
- Enter the required device information and complete the setup wizard.

Via App:

- Launch the PLANET CloudNMS App and sign in with your CloudNMS account.
- Create an Organization and a Network for the device, then go to the Add Device process.
- Enter the required device information or Scan the QR code of the device, and complete the setup wizard.

Web:

1. Create an Organization and a Network

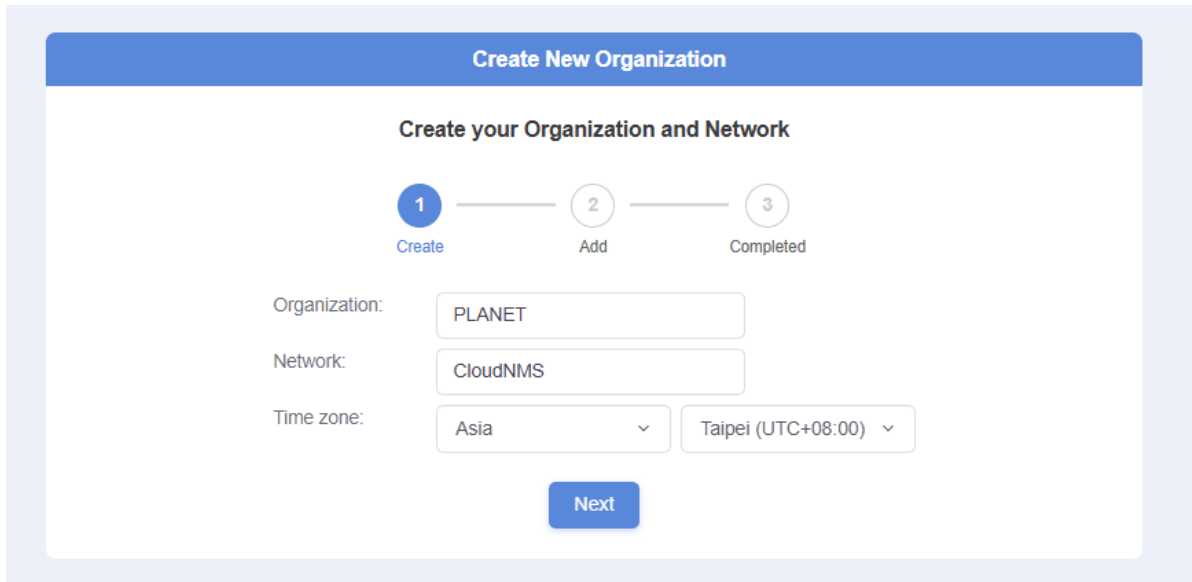

2. Enter the required device information

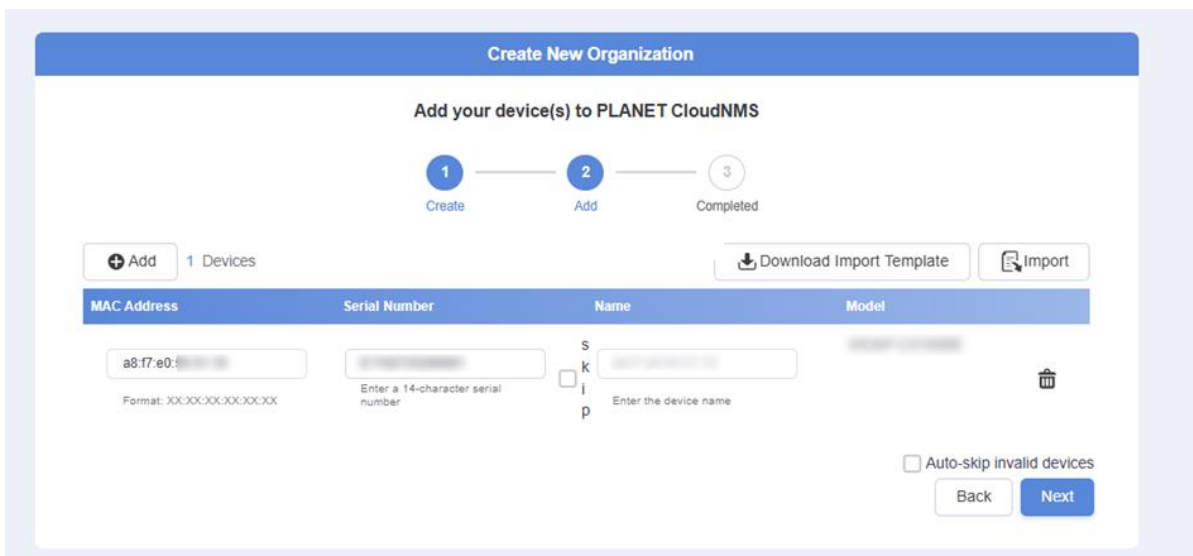

3. Finish

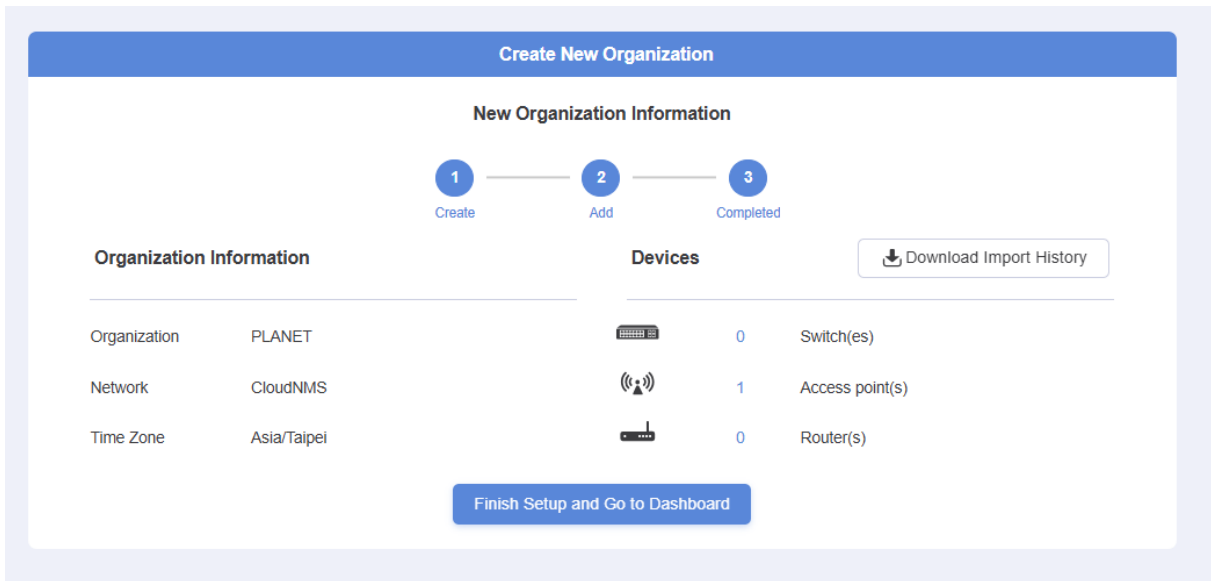

App:

1. Create an Organization and a Network



2. Enter the required device information or Scan QR code

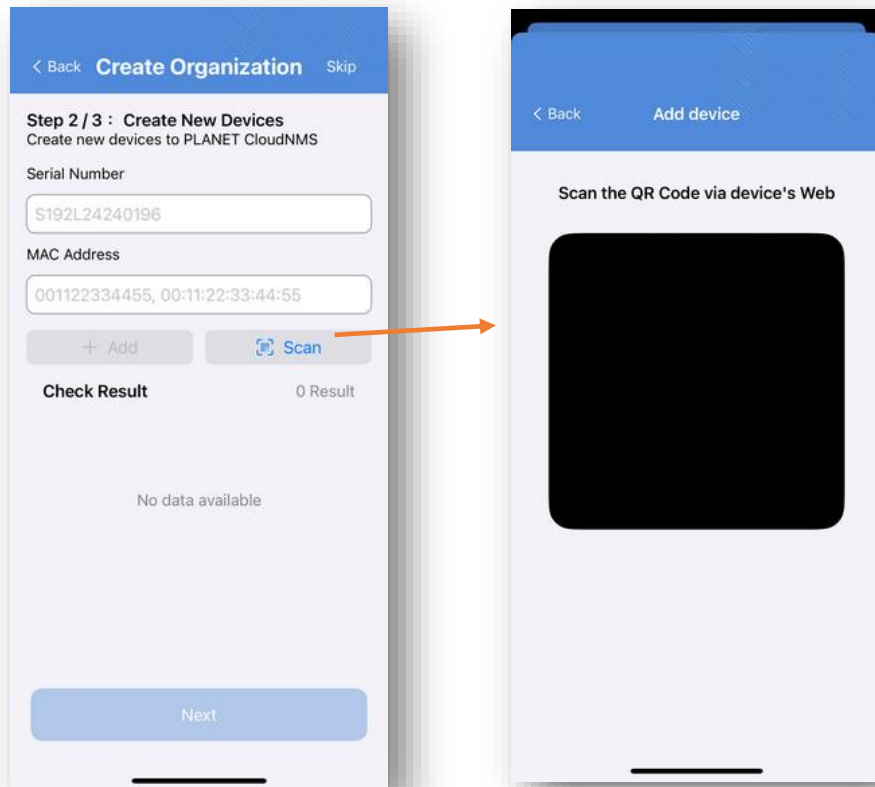

3. Finish



Step 5: Finish

Web:

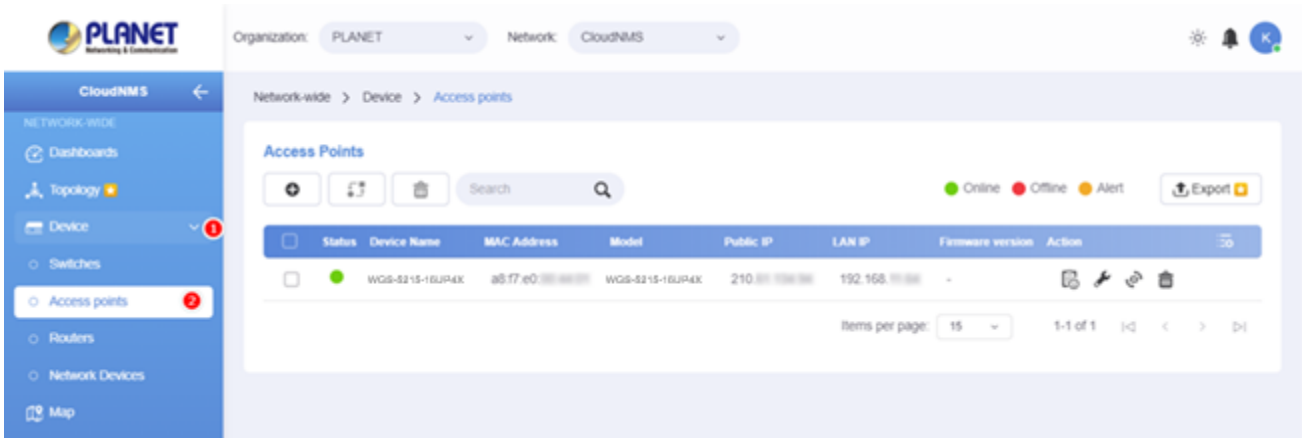

App:

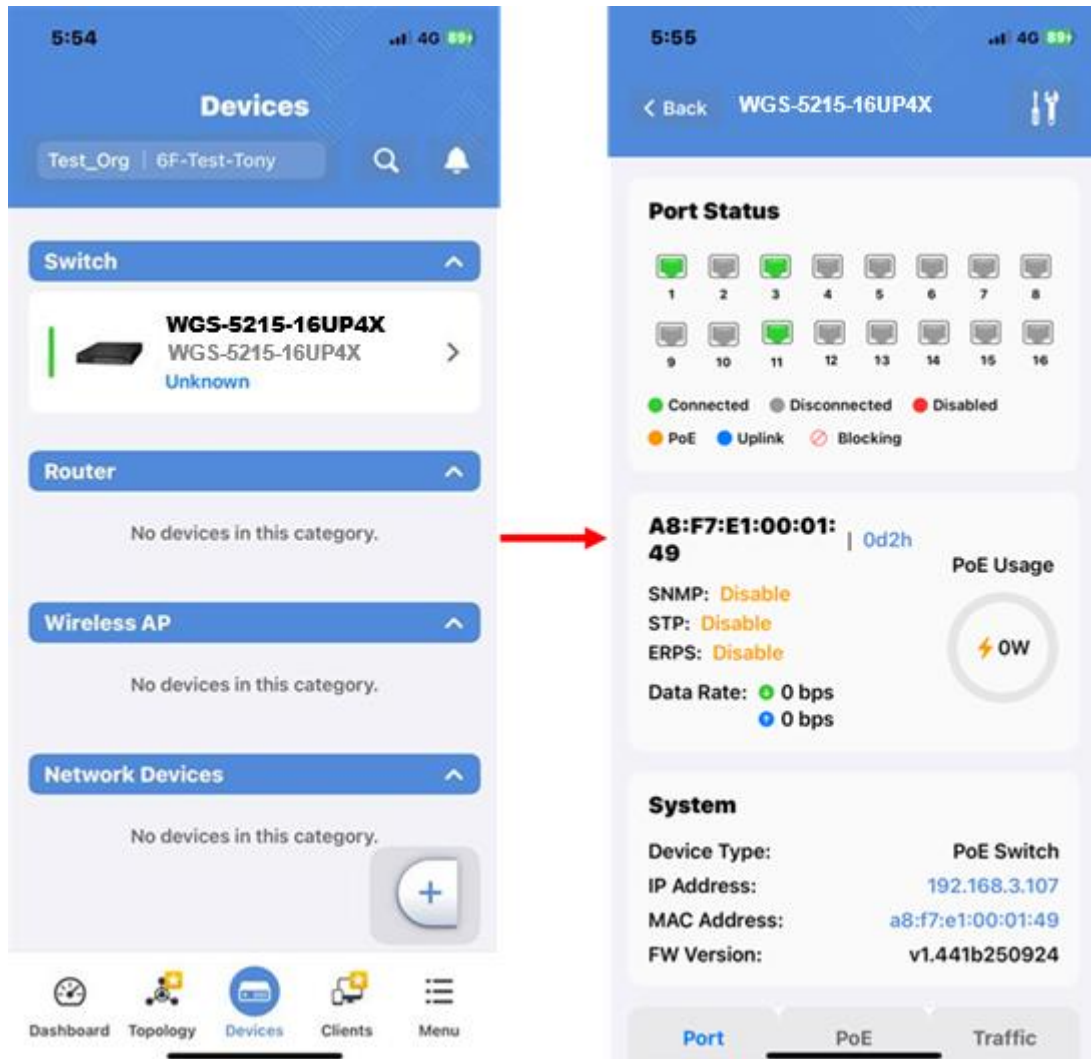

4.2.6 Radius

Remote Authentication Dial-In User Service (RADIUS) is a security authentication client/server protocol that supports authentication, authorization and accounting. The RADIUS Server page is shown in [Figure 4-2-7](#). [Table 4-2-10](#) describes the RADIUS Server objects of 10Gbps 802.3bt PoE++ Managed Injector Hub.

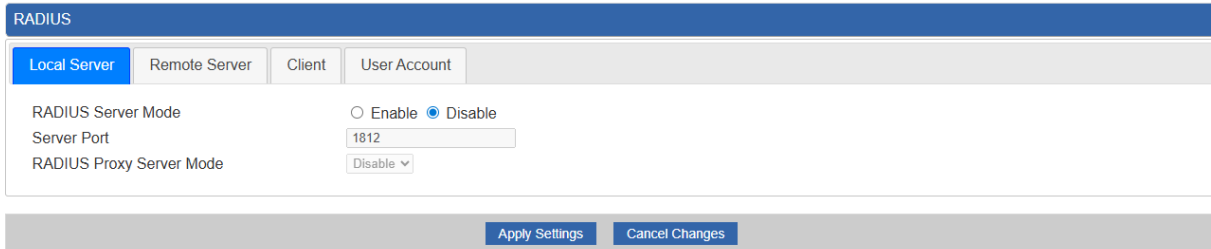

Figure 4-2-7: RADIUS Configuration Web Page Screen

Radius	
Object	Description
RADIUS Server Mode	Disable or enable the RADIUS function. The default configuration is disabled.
Server Port	Default: 1812.
RADIUS Proxy Server Mode	Disable or enable RADIUS Proxy Server Mode. The default configuration is disabled.

Table 4-2-10: Descriptions of the RADIUS Configuration Objects Screen

4.2.7 Remote Syslog

This section provides the Remote Syslog Setting of 10Gbps 802.3bt PoE++ Managed Injector Hub as the screen in [Figure 4-2-8](#). [Table 4-2-11](#) describes the Remote Syslog Setting objects of 10Gbps 802.3bt PoE++ Managed Injector Hub .

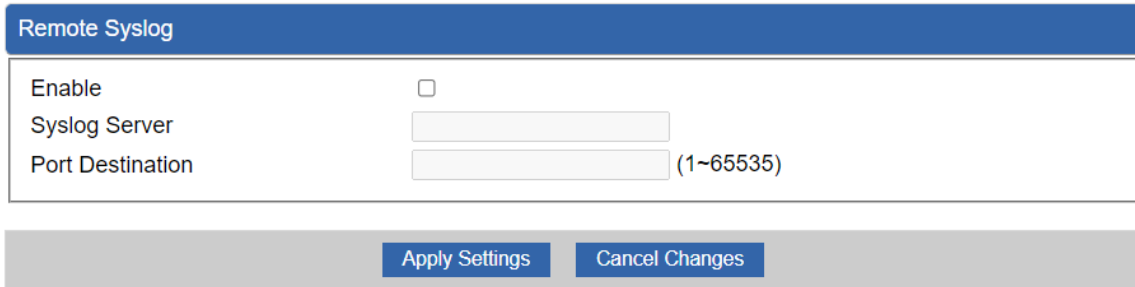

Figure 4-2-8: Remote Syslog Web Page

Remote Syslog	
Object	Description
Enable	Allows disable or enable Remote Syslog function of the 10Gbps 802.3bt PoE++ Managed Injector Hub.
Syslog Server	Input Syslog Server IP Address.
Port Destination	Input the Port Destination value and the available range is 1-65535.

Table 4-2-11: Descriptions of the Remote Syslog Objects Screen

4.2.8 Event Log

This section provides display system event log, the screen shown in [Figure 4-2-9](#).

[Table 4-2-12](#) describes the system event log objects of 10Gbps 802.3bt PoE++ Managed Injector Hub .

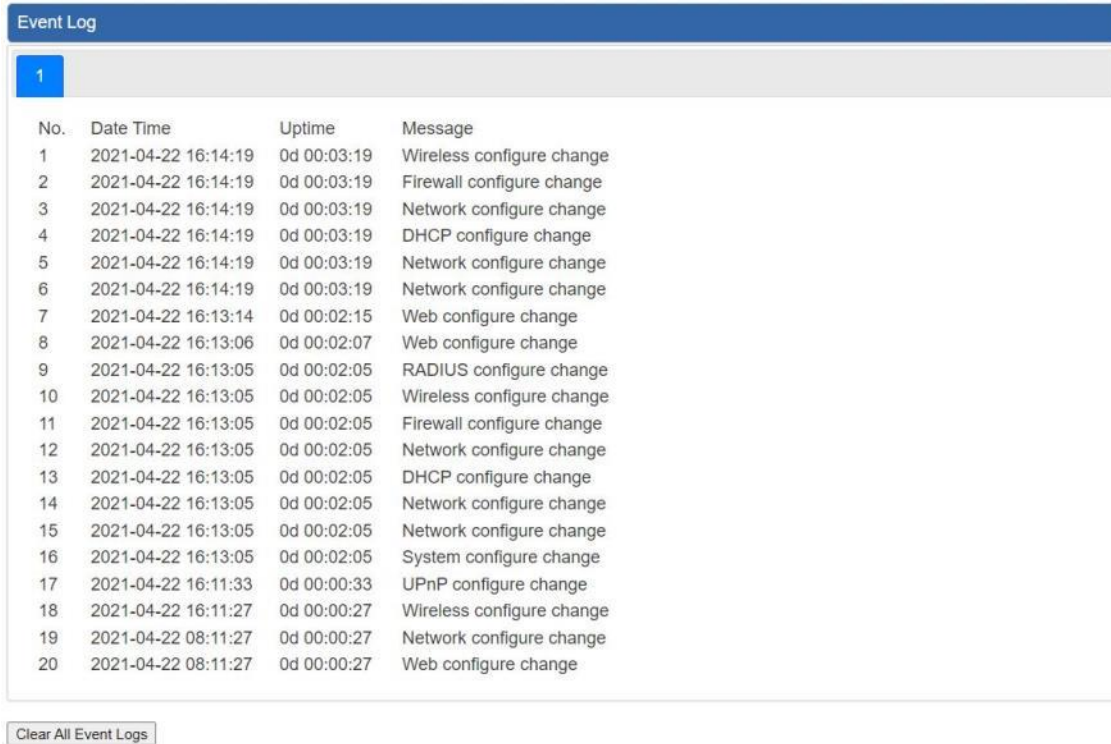

Figure 4-2-9: Event Log Web Page

Event Log	
Object	Description
Event Log	Display Event Log information.
<input type="button" value="Clear All Event Logs"/>	Clean all current event log information.

Table 4-2-12: Descriptions of the Event Log Objects Screen

4.3 Network

The Network function provides LAN, IPv6 and DDNS configuration of the 10Gbps 802.3bt PoE++ Managed Injector Hub as shown in [Figure 4-3-1](#).

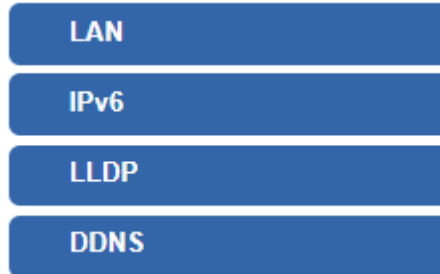

Figure 4-3-1: Network Menu

Network	
Object	Description
LAN	Allows setting LAN interface.
IPv6	Allows setting IPv6 interface.
LLDP	Allow setting LLDP.
DDNS	Allows setting DDNS and PLANET DDNS.

4.3.1 LAN

This page is used to configure the parameters for local area network which connects to the LAN port of your 10Gbps 802.3bt PoE++ Managed Injector Hub as shown in [Figure 4-3-2](#). Here you may change the settings for IP address, subnet mask, DNS, etc. [Table 4-3-1](#) describes the LAN object of 10Gbps 802.3bt PoE++ Managed Injector Hub .

LAN Configuration

Connection Type	<input type="text" value="Static"/>
IP Address	<input type="text" value="192.168.0.100"/>
Netmask	<input type="text" value="255.255.255.0"/>
Gateway	<input type="text" value="192.168.0.254"/>
Primary DNS	<input type="text" value="8.8.8.8"/>
Secondary DNS	<input type="text" value="8.8.4.4"/>
Second IP	<input type="radio"/> Enable <input checked="" type="radio"/> Disable
Second IP Address	<input type="text" value="0.0.0.0"/>
Second IP Netmask	<input type="text" value="0.0.0.0"/>

Figure 4-3-2: LAN Configuration Setup Web Page

LAN Configuration	
Object	Description
Connection Type	Provide Static and DHCP for IP connection type, the default is Static.
IP Address	The LAN IP address of the 10Gbps 802.3bt PoE++ Managed Injector Hub and default is 192.168.0.100 .
Netmask	Default is 255.255.255.0 .
Gateway	Default is 192.168.0.254 .
Primary DNS	Default is 8.8.8.8 .
Secondary DNS	Default is 8.8.4.4 .
Second IP	Provide Disable and Enable for second IP, the default is Disable.
Second IP Address	Default is 0.0.0.0 .
Second IP Netmask	Default is 0.0.0.0 .
Apply Settings	Save current configuration.
Cancel Settings	Ignore current configuration.

Table 4-3-1: Descriptions of the LAN Configuration Objects Screen

4.3.2 IPv6

This page is used to configure parameter for IPv6 internet network which connects to LAN port of the 10Gbps 802.3bt PoE++ Managed Injector Hub as shown in [Figure 4-3-3](#). It allows you to enable IPv6 function and set up the parameters of the 10Gbps 802.3bt PoE++ Managed Injector Hub 's LAN. In this setting you may change LAN connection type and other settings.

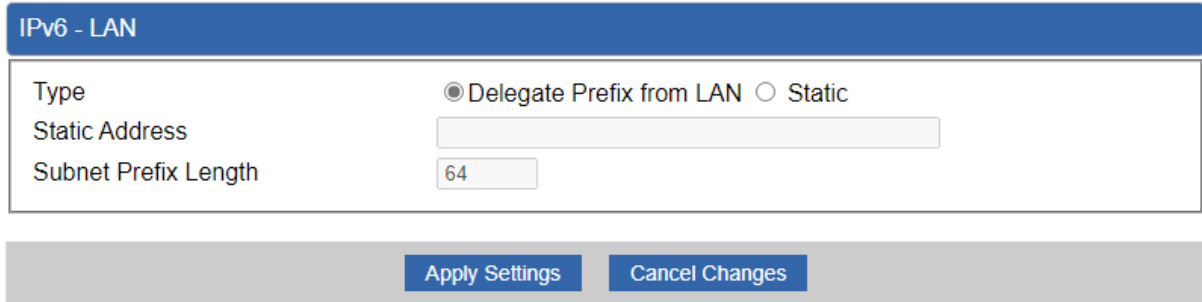

Figure 4-3-3: IPv6-LAN Web Page

IPv6 – LAN	
Object	Description
Type	Select IPv6 type either by using DHCP or Static.
Static Address	Enter the IPv6 address.
Subnet Prefix Length	Enter the subnet prefix length.

Table 4-3-2: Descriptions of the IPv6 Configuration Objects Screen

4.3.3 LLDP

This page is used to configure parameter for LLDP function of the 10Gbps 802.3bt PoE++ Managed Injector Hub as shown in [Figure 4-3-4](#). It allows you to enable LLDP function and set up the parameters of the 10Gbps 802.3bt PoE++ Managed Injector Hub.

LLDP Configuration

LLDP	<input type="radio"/> Enable <input checked="" type="radio"/> Disable	
Transmission Interval	<input style="width: 100px;" type="text" value="30"/>	(5~32767) seconds
Holdtime Multiplier	<input style="width: 100px;" type="text" value="4"/>	(2~10) times
Reinitialization Delay	<input style="width: 100px;" type="text" value="2"/>	(1~10) seconds
Transmit Delay	<input style="width: 100px;" type="text" value="2"/>	(1~8191) seconds

Apply Settings
Cancel Changes

Figure 4-3-4: LLDP Configuration Web Page

LLDP Configuration	
Object	Description
LLDP	Enable or Disable LLDP Function.
Transmission Interval	Configure transmission interval value and the available range is (5~32767) seconds.
Holdtime Multiplier	Configure holdtime multiplier value and the available range is (2~10) times.
Reinitialization Delay	Configure reinitialization delay value and the available range is (1-10) seconds.
Transmit Delay	Configure transmission delay value and the available range is (1~8191) seconds.

Table 4-3-3: Descriptions of the LLDP Configuration Objects Screen

4.3.4 DDNS

The 10Gbps 802.3bt PoE++ Managed Injector Hub offers the DDNS (Dynamic Domain Name System) feature, which allows the hosting of a website, FTP server, or e-mail server with a fixed domain name (named by yourself) and a dynamic IP address, and then your friends can connect to your server by entering your domain name no matter what your IP address is. Before using this feature, you need to sign up for DDNS service providers such as **PLANET DDNS** (<https://www.planetddns.com>) and set up the domain name of your choice.

PLANET DDNS website provides a free DDNS (Dynamic Domain Name Server) service for PLANET devices. Whether the IP address used on your PLANET device supporting DDNS service is fixed or dynamic, you can easily connect the devices anywhere on the Internet with a meaningful or easy-to-remember name you gave. PLANET DDNS provides two types of DDNS services. One is **PLANET DDNS** and the other is **PLANET Easy DDNS** as shown in [Figure 4-3-5](#).

PLANET DDNS

For example, you've just installed a PLANET IP camera with dynamic IP like 210.66.155.93 in the network. You can name this device as "Mycam1" and register a domain as Mycam1.planetddns.com at PLANET DDNS (<https://www.planetddns.com>). Thus, you don't need to memorize the exact IP address but just the URL link: Mycam1.planetddns.com.

PLANET Easy DDNS

PLANET Easy DDNS is an easy way to help user to get your Domain Name with just one click. You can just log in to the Web Management Interface of your devices, say, your 10Gbps 802.3bt PoE++ Managed Injector Hub, and check the DDNS menu and just enable it. You don't need to go to <https://www.planetddns.com> to apply for a new account. Once you enabled the Easy DDNS, your

PLANET Network Device will use the format PLxxxxxx where xxxxxx is the last 6 characters of your MAC address that can be found on the Web page or bottom label of the device. (For example, if the 10Gbps 802.3bt PoE++ Managed Injector Hub's MAC address is A8-F7-E0-81-96-C9, it will be converted into pt8196c9.planetddns.com)

DDNS Configuration

Dynamic DNS	<input type="radio"/> Enable <input checked="" type="radio"/> Disable
Interface	<input type="text" value="LAN"/>
DDNS Type	<input type="text" value="PLANET DDNS"/>
PLANET Easy DDNS	<input type="text" value="Disable"/>
User Name	<input type="text"/>
Password	<input type="text"/>
Host Name	<input type="text"/>
Interval	<input type="text" value="120"/> seconds
Connection Status	Not enabled

Figure 4-3-5: PLANET DDNS Configuration Web Page

DDNS Configuration	
Object	Description
DDNS Service	By default, the DDNS service is disabled. If user needs to enable the function, please set it as enable.
Interface	User is able to select the interface for DDNS service. By default, the interface is LAN.
DDNS Type	There are three options: 1. PLANET DDNS: Activate PLANET DDNS service. 2. DynDNS: Activate DynDNS service. 3. NOIP: Activate NOIP service. Note that please first register with the DDNS service and set up the domain name of your choice to begin using it.
PLANET Easy DDNS	When the PLANET DDNS service is activated, user is able to select to enable or disable Easy DDNS. When this function is enabled, DDNS hostname will appear automatically. User doesn't go to https://www.planetddns.com to apply for a new account.
User Name	The user name is used to log into DDNS service.
Password	The password is used to log into DDNS service.
Host Name	The host name as registered with your DDNS provider.
Interval	Set the update interval of the DDNS function.
Connection Status	Show the connection status of the DDNS function.

Table 4-3-4: Descriptions of the PLANET DDNS Configuration Objects Screen

4.4 Security

The Security menu provides Firewall, Access Filtering and other functions as shown in [Figure 4-4-1](#). Please refer to the following sections for the details.

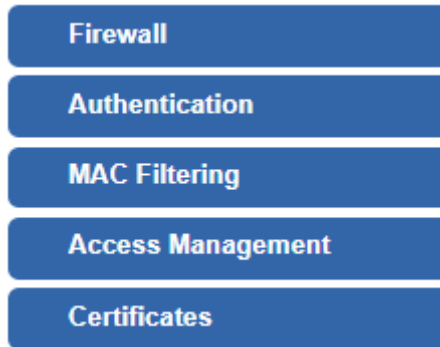

Figure 4-4-1: Security Menu

Security	
Object	Description
Firewall	Allows setting DoS (Denial of Service) protection as enable.
Authentication	Authentication Method Configuration.
MAC Filtering	Allows setting MAC Filtering.
Access Management	Access Management Configuration.
Certificates	Allows download System CA Certificate.

4.4.1 Firewall

A "Denial-of-Service" (DoS) attack is characterized by an explicit attempt by hackers to prevent legitimate users of a service from using that service. The 10Gbps 802.3bt PoE++ Managed Injector Hub can prevent specific DoS attacks as shown in [Figure 4-4-2](#). [Table 4-4-1](#) describes the Firewall object of 10Gbps 802.3bt PoE++ Managed Injector Hub.

Firewall Protection

SPI Firewall Enable Disable

DDoS

Block SYN Flood	<input checked="" type="radio"/> Enable <input type="radio"/> Disable	<input type="text" value="30"/>	Packets/Second
Block FIN Flood	<input type="radio"/> Enable <input checked="" type="radio"/> Disable	<input type="text" value="30"/>	Packets/Second
Block UDP Flood	<input type="radio"/> Enable <input checked="" type="radio"/> Disable	<input type="text" value="30"/>	Packets/Second
Block ICMP Flood	<input type="radio"/> Enable <input checked="" type="radio"/> Disable	<input type="text" value="5"/>	Packets/Second
Block IP Teardrop Attack	<input type="radio"/> Enable <input checked="" type="radio"/> Disable		
Block Ping of Death	<input type="radio"/> Enable <input checked="" type="radio"/> Disable		
Block TCP packets with SYN and FIN Bits set	<input type="radio"/> Enable <input checked="" type="radio"/> Disable		
Block TCP packets with FIN Bit set but no ACK Bit set	<input type="radio"/> Enable <input checked="" type="radio"/> Disable		
Block TCP packets without Bits set	<input type="radio"/> Enable <input checked="" type="radio"/> Disable		

System Security

HTTP Port	<input type="text" value="80"/>	<input checked="" type="radio"/> Enable <input type="radio"/> Disable
HTTPS Port	<input type="text" value="443"/>	<input checked="" type="radio"/> Enable <input type="radio"/> Disable
Redirect HTTP to HTTPS	<input type="radio"/> Enable <input checked="" type="radio"/> Disable	
Temporarily block when login failed more than	<input type="text" value="0"/>	(0 means no limit)
IP blocking period	<input type="text" value="0"/>	minute(s) (0 means permanent blocking)
Blocked IP	0.0.0.0	

Apply Settings
Cancel Changes

Figure 4-4-2: Firewall Protection Web Page

Firewall Protection	
Object	Description
SPI Firewall	The SPI Firewall prevents attack and improper access to network resources. The default configuration is enabled.
Block SYN Flood	SYN Flood is a popular attack way. DoS and DDoS are TCP protocols. Hackers like using this method to make a fake connection that involves the CPU, memory, and so on. The default configuration is enabled.
Block FIN Flood	If the function is enabled, when the number of the current FIN packets is beyond the set value, the 10Gbps 802.3bt PoE++ Managed Injector Hub will start the blocking function immediately. The default configuration is disabled.
Block UDP Flood	If the function is enabled, when the number of the current UPD-FLOOD packets is beyond the set value, the 10Gbps 802.3bt PoE++ Managed Injector Hub will start the blocking function immediately. The default configuration is disabled.
Block ICMP Flood	ICMP is kind of a pack of TCP/IP; its important function is to transfer simple signal on the Internet. There are two normal attack ways which hackers like to use, Ping of Death and Smurf attack. The default configuration is disabled.
IP TearDrop Attack	If the function is enabled, the 10Gbps 802.3bt PoE++ Managed Injector Hub will block Teardrop attack that is targeting on TCP/IP fragmentation reassembly codes.
Block Ping Of Death	If the function is enabled, the 10Gbps 802.3bt PoE++ Managed Injector Hub will block Ping of Death attack that aims to disrupt a targeted machine by sending a packet larger than the maximum allowable size causing the target machine to freeze or crash.
Block TCP packets with SYN and FIN Bits set	Set the function as enable or disable.
Block TCP packets with FIN Bit set but no ACK Bit set	Set the function as enable or disable.
Block TCP packets without Bits set	Set the function as enable or disable.
System Security	
Object	Description
HTTP Port	The default is 80, also set the function as enable or disable.
HTTPs Port	The default is 443, also set the function as enable or disable.
Redirect HTTP to HTTPS	Set the function as enable or disable.
Temporarily block when login failed	The default is 0. (0 means no limit).
IP blocking period	The default is 0. (0 means permanent blocking).
Blocked IP	0.0.0.0.

Table 4-4-1: Descriptions of the Firewall Protection Objects Screen

4.4.2 Authentication

Entries in this table are used to configure the HTTP authentication methods of the 10Gbps 802.3bt PoE++ Managed Injector Hub. Use of such methods can be helpful in securing access via web interface of 10Gbps 802.3bt PoE++ Managed Injector Hub, the screen as shown in [Figure 4-4-3](#). [Table 4-4-2](#) describes the authentication object of 10Gbps 802.3bt PoE++ Managed Injector Hub.

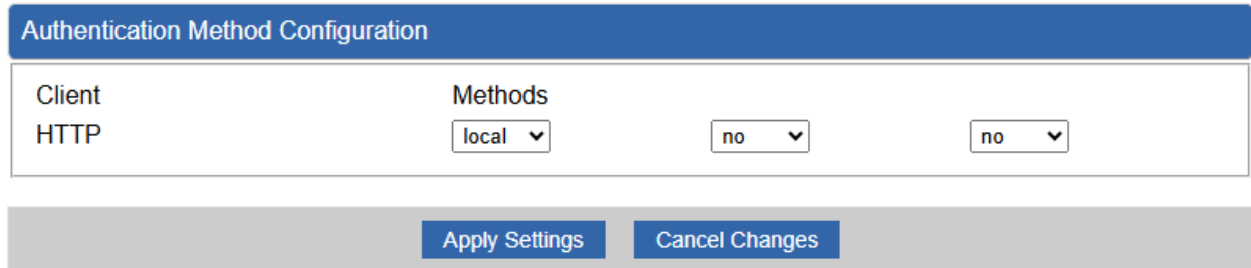

Authentication Method Configuration		
Client	Methods	
HTTP	local ▼	no ▼

Figure 4-4-3: Authentication Web Page

Authentication	
Object	Description
Client (HTTP)	Display the Client HTTP information.
Methods	Select the function works on authentication methods, such as no, local and radius.

Table 4-4-2: Descriptions of the Authentication Objects Screen

4.4.3 MAC Filtering

Entries in this table are used to restrict certain types of data packets from your local network or Internet through the 10Gbps 802.3bt PoE++ Managed Injector Hub. Use of such filters can be helpful in securing or restricting your local network as shown in Figure 4-4-4. Table 4-4-3 describes the MAC filtering object of 10Gbps 802.3bt PoE++ Managed Injector Hub.

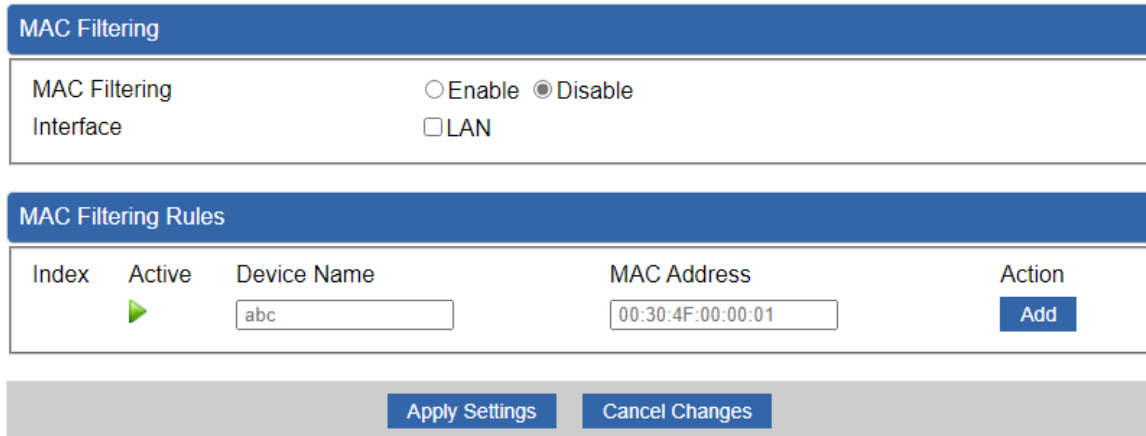

Figure 4-4-4: MAC Filtering Web Page

MAC Filtering	
Object	Description
Enable MAC Filtering	Set the function as enable or disable. When the function is enabled, the 10Gbps 802.3bt PoE++ Managed Injector Hub will block traffic of the MAC address on the list.
Interface	Select the function works on LAN. To block a LAN device's MAC address.
MAC Address	Input a MAC address you want to control, such as A8:F7:E0:00:06:62.
Add	When you input a MAC address, please click the "Add" button to add it into the list.

Table 4-4-3: Descriptions of the MAC Filtering Objects Screen

4.4.4 Access Management

Entries in this table are used to restrict certain users with specific IP address to access the 10Gbps 802.3bt PoE++ Managed Injector Hub. Use of such function can be helpful in securing access of the 10Gbps 802.3bt PoE++ Managed Injector Hub, the screen as shown in [Figure 4-4-5](#). [Table 4-4-4](#) describes the access management object of 10Gbps 802.3bt PoE++ Managed Injector Hub.

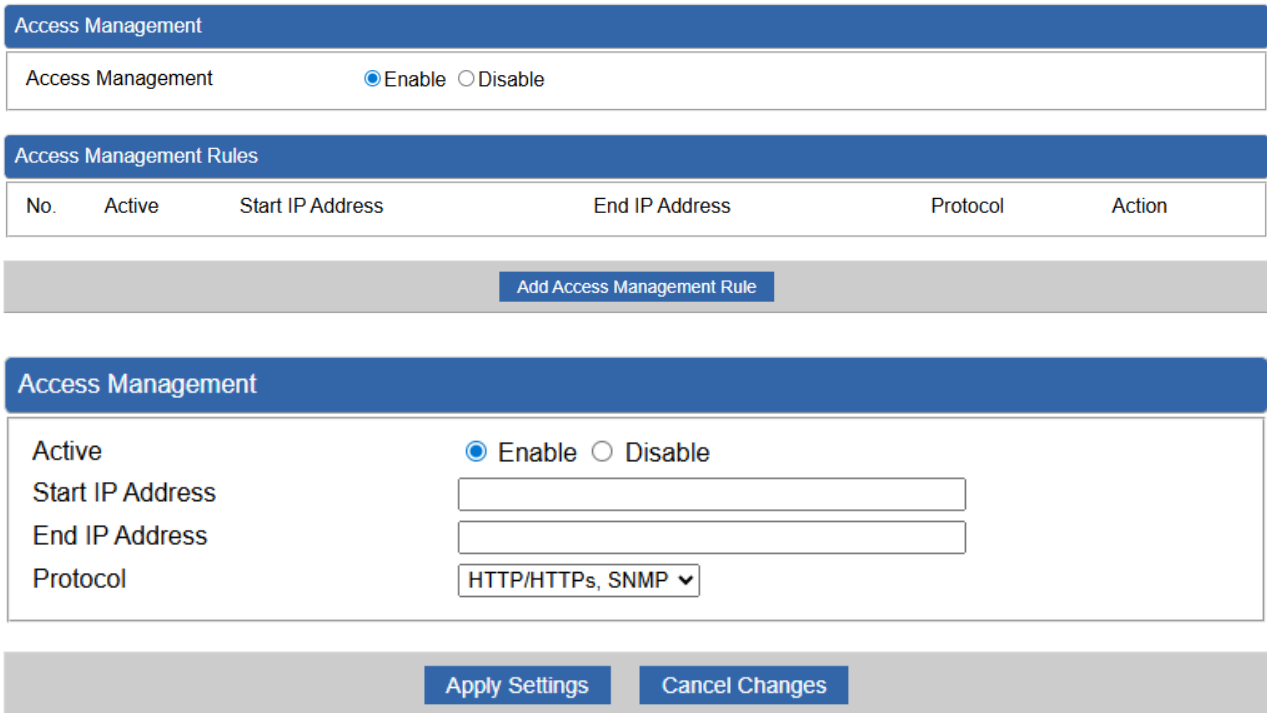

The screenshot shows the 'Access Management' web page. At the top, there is a section titled 'Access Management' with a toggle for 'Access Management' set to 'Enable'. Below this is a section titled 'Access Management Rules' which contains a table with columns: No., Active, Start IP Address, End IP Address, Protocol, and Action. A button 'Add Access Management Rule' is located below the table. The bottom part of the screenshot shows the configuration form for a rule, with fields for 'Active' (set to 'Enable'), 'Start IP Address', 'End IP Address', and 'Protocol' (set to 'HTTP/HTTPs, SNMP'). At the bottom of the form are buttons for 'Apply Settings' and 'Cancel Changes'.

Figure 4-4-5: Access Management Web Page

Access Management	
Object	Description
Access Management	Set the function as enable or disable. When the function is enabled, the 10Gbps 802.3bt PoE++ Managed Injector Hub will block access of the IP address not on the list.
Access Management Rules	
Object	Description
No.	Display the number information.
Active	Display the active status.
Start IP Address	Display the start IP address information.
End IP Address	Display the end IP address information.
Protocol	Display the HTTP, HTTPS and SNMP.
Action	Provide edit or delete existence access management rules.
Add Access Management Rules	
Object	Description
Active	Enable or disable access management function.
Start IP Address	Input the start IP address.
End IP Address	Input the end IP address.

Access Management	
Object	Description
Protocol	Provide the HTTP, HTTPS and SNMP options, the available options are shown below: HTTP/HTTPs, SNMP HTTP/HTTPs SNMP

Table 4-4-4: Descriptions of the Access Management Objects Screen

4.4.5 Certificates

This web page provides to download the certificates and shown in [Figure 4-4-6](#). [Table 4-4-5](#) describes the Certificates object of 10Gbps 802.3bt PoE++ Managed Injector Hub.

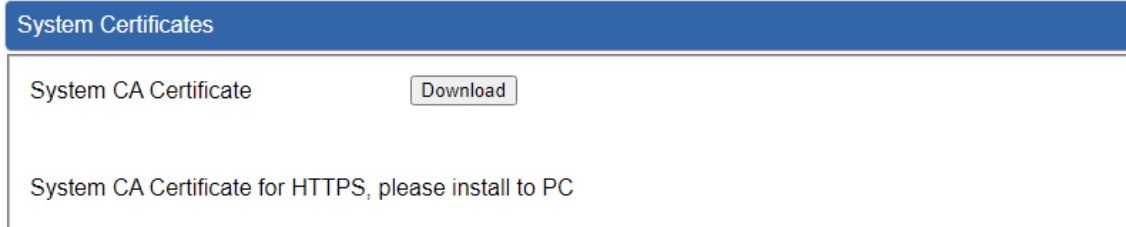

Figure 4-4-6: System Certificates Web Page

System Certificates	
Object	Description
Download	Press this button to download the system CA certificate file.

Table 4-4-5: Descriptions of the System Certificates Objects Screen

4.5 PoE

The PoE menu provides PoE Configuration, PoE Status, PoE Schedule and PoE Alive Check as shown in [Figure 4-5-1](#). Please refer to the following sections for the details.

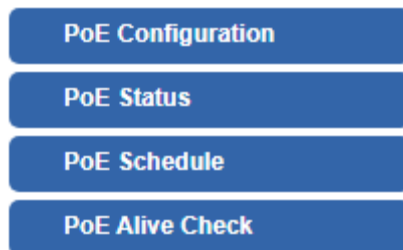

Figure 4-5-1: PoE Menu

PoE	
Object	Description
PoE Configuration	Allow to centralize management PoE power for PDs
PoE Status	Display the current PoE usage.
PoE Shedule	Allow to centralize management PoE power for providing schedule.
PoE Alive Check	Allow to centralize management PoE power for checking PDs alive.

PoE Power Budget list for 10Gbps 802.3bt PoE++ Managed Injector Hub Series.

Model	Per PoE Power Output	PoE Standard	Total PoE Budget
UPOE-800G	95 watts	IEEE 802.3bt PoE++ IEEE 802.3at PoE+	400 watts
UPOE-1600G			600 watts
UPOE-2400G			800 watts

4.5.1 PoE Configuration

This section provides PoE (Power over Ethernet) Configuration and PoE output status of 10Gbps 802.3bt PoE++ Managed Injector Hub ; screen in [Figure 4-5-2](#) appears. Table 4-5-1 describes the PoE Configuration object of 10Gbps 802.3bt PoE++ Managed Injector Hub

PoE Configuration

System PoE Admin Mode Enable ▾

Power Supply 54 V

Power Limit Mode Consumption ▾

Smart Fan Low Speed

Power Allocation 0 / 600 W

Port	Description	PoE Function	Schedule	Power Mode	Power Type	Priority	Device Class	Current Used [mA]	Powered Used [W]	Power Limit [W]
All		<All> ▾	<All> ▾	<All> ▾	<All> ▾	<All> ▾				
1		Enable ▾	None ▾	BT ▾	Standard ▾	High ▾	--	0	0	95
2		Enable ▾	None ▾	BT ▾	Standard ▾	High ▾	--	0	0	95
3		Enable ▾	None ▾	BT ▾	Standard ▾	High ▾	--	0	0	95
4		Enable ▾	None ▾	BT ▾	Standard ▾	High ▾	--	0	0	95
5		Enable ▾	None ▾	BT ▾	Standard ▾	High ▾	--	0	0	95
6		Enable ▾	None ▾	BT ▾	Standard ▾	High ▾	--	0	0	95
7		Enable ▾	None ▾	BT ▾	Standard ▾	High ▾	--	0	0	95
8		Enable ▾	None ▾	BT ▾	Standard ▾	High ▾	--	0	0	95
9		Enable ▾	None ▾	BT ▾	Standard ▾	High ▾	--	0	0	95
10		Enable ▾	None ▾	BT ▾	Standard ▾	High ▾	--	0	0	95
11		Enable ▾	None ▾	BT ▾	Standard ▾	High ▾	--	0	0	95
12		Enable ▾	None ▾	BT ▾	Standard ▾	High ▾	--	0	0	95
13		Enable ▾	None ▾	BT ▾	Standard ▾	High ▾	--	0	0	95
14		Enable ▾	None ▾	BT ▾	Standard ▾	High ▾	--	0	0	95
15		Enable ▾	None ▾	BT ▾	Standard ▾	High ▾	--	0	0	95
16		Enable ▾	None ▾	BT ▾	Standard ▾	High ▾	--	0	0	95
Total								0	0	

Apply Settings
Cancel Changes

Figure 4-5-2: PoE Configuration Web Page

Object	Description
• System PoE Admin Mode	Allows user to disable/enable PoE function.
• Power Supply	Displays PoE power supply status.
• Power Limit Mode	Allows user to configure power limit mode, which can be chosen. Consumption: Based on the real device power consumption where PoE power is delivered as system default setting is in this mode. Classification: Based on port priority setting and device class where PoE power is delivered.
• Smart Fan	Display Smart Fan operation status.
• Power Allocation	Displays the current total power consumption status.
• Description	This function provides input per port description and the available letters is 30. NOTE: The total maximum letters are only 800. Some of special words will count as 5 per word, like ' , " , \ , < and >.
• PoE Function	Allows user to disable or enable per port PoE function.
• PoE Schedule	Indicates the scheduled profile mode. Possible profiles are: <ul style="list-style-type: none"> ■ None(Dafault) ■ Profile1 ■ Profile2 ■ Profile3 ■ Profile4
• Power Mode	Indicates the PoE power mode. The available options are: <ul style="list-style-type: none"> ■ End-span ■ Mid-span ■ BT (Default)
• Power Type	Indicates the PoE power type. The available options are: <ul style="list-style-type: none"> ■ Standard(Default) ■ Legacy ■ Force <p>802.3bt (Standard) Fully conforms to the IEEE 802.3af/at/bt standard.</p> <p>Legacy The legacy detection is to identify the valid current signature of the PDs that do not fully follow the IEEE 802.3af/at/bt standard. This protects against damage to the PDs as the right PoE mode is applied.</p> <p>Force If the output power of injector is less than 1 watt when it works as Legacy mode, after 20 seconds, the Force mode will be enabled. When the Force mode is enabled, it will provide PD with a maximum of 90~95 watts. If the output power of injector is less than 1 watt when it works as Force mode, after 2 seconds, the Legacy mode will be enabled.</p>
• Priority	Allows user to set PoE port priority. There are 3 levels that could be configured and they are Critical, High and Low. The Critical is the highest priority and Low is the lowest priority. This function is worked under Priority power limit mode only.
• Device Class	Displays PoE class level. The IEEE 802.3af standard offers PoE class level from 1 to 3 and IEEE 802.3at standard offers the class from 1 to 4 .
• Current Used [mA]	Displays PoE device current.

• Power Used [W]	Displays PoE device power consumption.
• Power Limit [W]	Allows user to custom-power for port. This function is worked under Total Limit power limit mode. This function is also related to Power Mode . If Power mode is End-span or Mid-span 802.3at, then user can allocate to 36 watts at the maximum; otherwise, user can allocate to 95 watts.
• Apply	Press this button to take effect.

Table 4-5-1: Descriptions of the PoE Configuration Objects Screen

4.5.2 PoE Status

This page displays to per port PoE usage status, the screen in [Figure 4-5-3](#) appears.

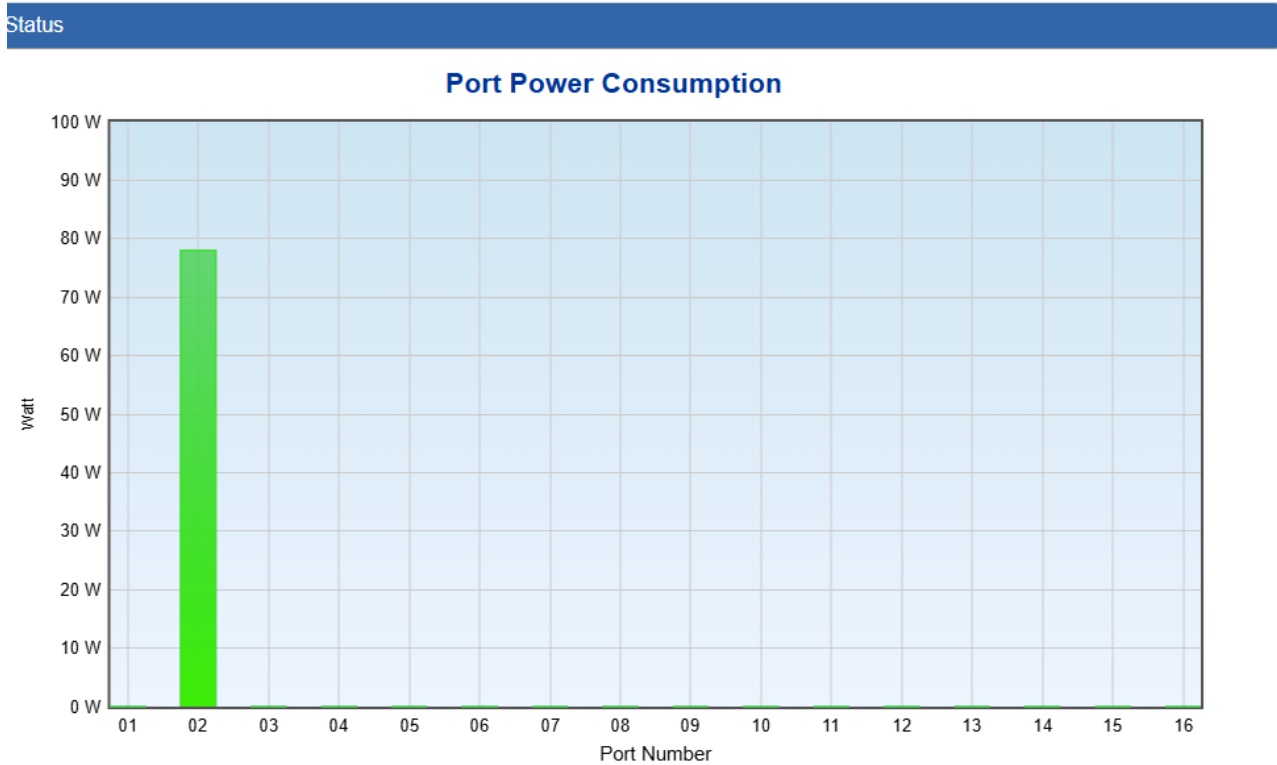

Figure 4-5-3: PoE Status Screenshot

The page includes the following fields:

PoE Status	
Object	Description
Port Number	Displays per port status.
Watt	Displays per port PoE usage.

Table 4-5-2: Descriptions of the PoE Status Objects Screen

4.5.3 PoE Schedule

This page allows the user to define PoE schedule and scheduled power recycling.

PoE Schedule

Besides being used as an IP Surveillance, the 10Gbps 802.3bt PoE++ Managed Injector Hub is certainly applicable to construct any PoE network including VoIP and Wireless LAN. Under the trend of energy saving worldwide and contributing to the environmental protection on the Earth, the 10Gbps 802.3bt PoE++ Managed Injector Hub can effectively control the power supply besides its capability of giving high watts power. The "PoE schedule" function helps you to enable or disable PoE power feeding for each PoE port during specified time intervals and it is a powerful function to help SMB or Enterprise saving power and money.

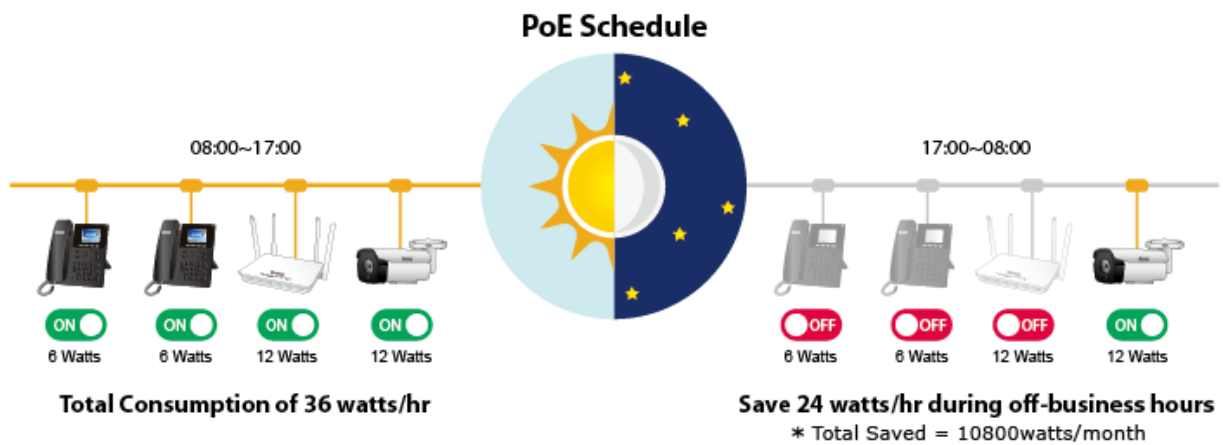

Scheduled Power Recycling

The 10Gbps 802.3bt PoE++ Managed Injector Hub allows each of the connected PoE IP cameras to reboot at a specified time each week. Therefore, it will reduce the chance of IP camera crash resulting from buffer overflow.

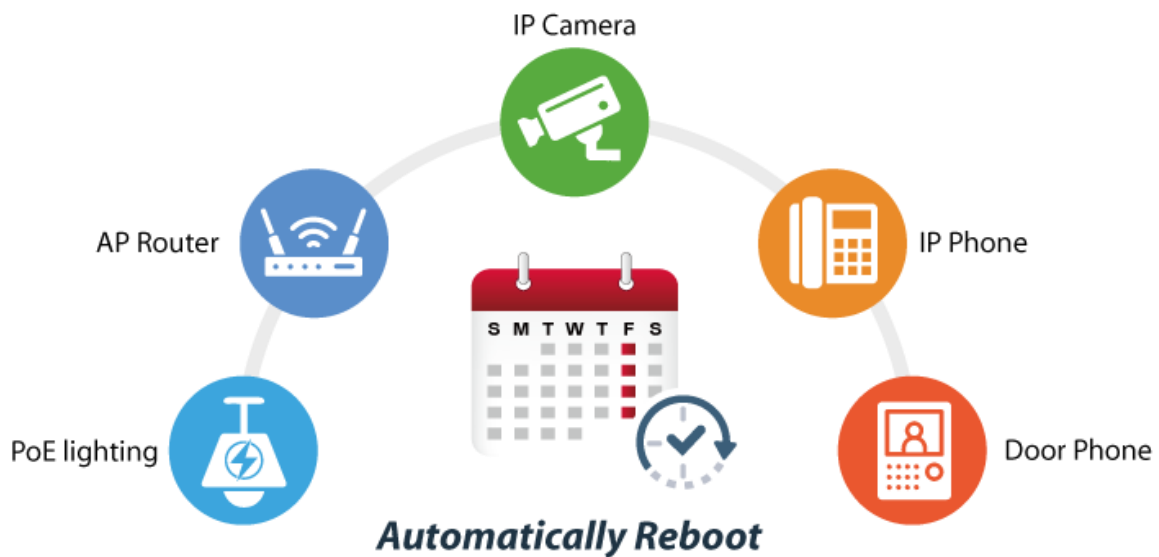

The screen in Figure 4-5-4 appears.

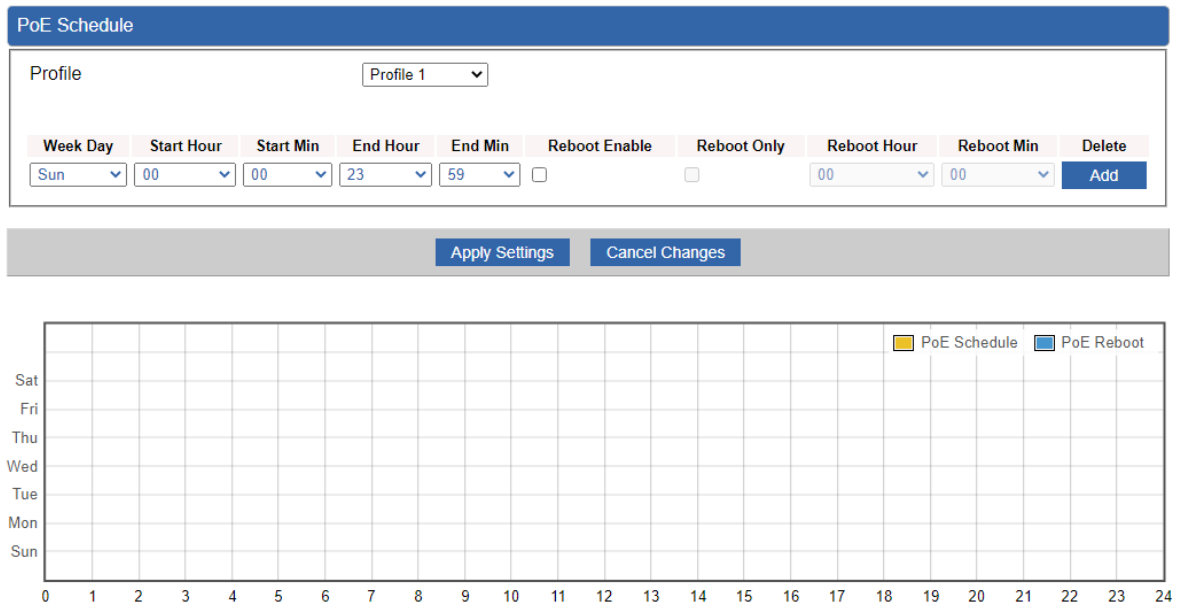

Figure 4-5-4: PoE Schedule Screenshot

Please press **Add** button to start setting PoE Schedule function. You have to set PoE schedule to profile and then go back to PoE Port Configuration, and select “**Schedule**” mode from per port “**PoE Mode**” option to enable you to indicate which schedule profile could be applied to the PoE port.

The page includes the following fields:

PoE Schedule	
Object	Description
Profile	Set the schedule profile mode. Possible profiles are: Profile1 Profile2 Profile3 Profile4
Week Day	Allows user to set week day for defining PoE function by enabling it on the day.
Start Hour	Allows user to set what hour PoE function does by enabling it.
Start Min	Allows user to set what minute PoE function does by enabling it.
End Hour	Allows user to set what hour PoE function does by disabling it.
End Min	Allows user to set what minute PoE function does by disabling it.
Reboot Enable	Allows user to enable or disable the whole PoE port reboot by PoE reboot schedule. Please note that if you want PoE schedule and PoE reboot schedule to work at the same time, please use this function, and don't use Reboot Only function. This function offers administrator to reboot PoE device at an indicated time if administrator has this kind of requirement.
Reboot Only	Allows user to reboot PoE function by PoE reboot schedule. Please note that if administrator enables this function, PoE schedule will not set time to profile. This function is just for PoE port to reset at an indicated time.
Reboot Hour	Allows user to set what hour PoE reboots. This function is only for PoE reboot schedule.
Reboot Min	Allows user to set what minute PoE reboots. This function is only for PoE reboot schedule.

Table 4-5-3: Descriptions of the PoE Schedule Objects Screen

4.5.4 PoE Alive Check

The 10Gbps 802.3bt PoE++ Managed Injector Hub can be configured to monitor connected PD's status in real-time via ping action. Once the PD stops working and without response, the 10Gbps 802.3bt PoE++ Managed Injector Hub is going to restart PoE port power, and bring the PD back to work. It will greatly enhance the reliability and reduces administrator management burden.

PD Alive Check

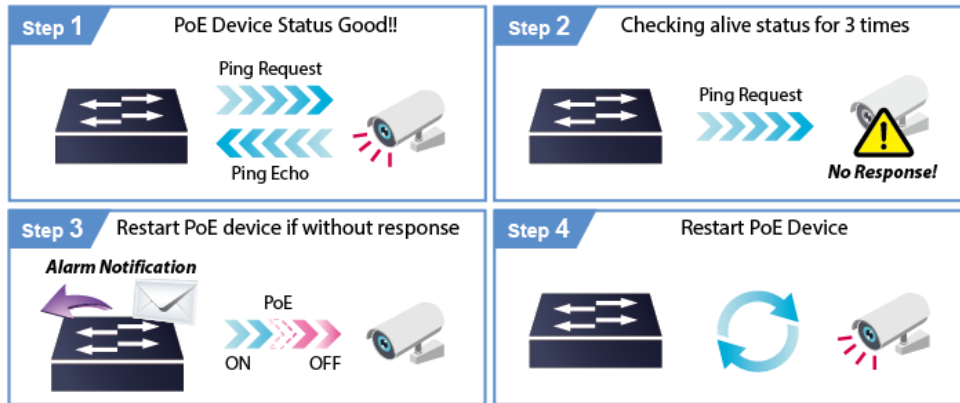

This page provides you with how to configure PD Alive Check. The screen in [Figure 4-5-5](#) appears.

PoE Alive Configuration

Port	Mode	Remote PD IP Address	Interval Time(2~300s)	Retry Count(1~5)	Action	Reboot Time (5~180s)
All	<All>			<All>	<All>	
1	Disable	192.168.0.10	10	1	None	30
2	Disable	192.168.0.11	10	1	None	30
3	Disable	192.168.0.12	10	1	None	30
4	Disable	192.168.0.13	10	1	None	30
5	Disable	192.168.0.14	10	1	None	30
6	Disable	192.168.0.15	10	1	None	30
7	Disable	192.168.0.16	10	1	None	30
8	Disable	192.168.0.17	10	1	None	30
9	Disable	192.168.0.18	10	1	None	30
10	Disable	192.168.0.19	10	1	None	30
11	Disable	192.168.0.20	10	1	None	30
12	Disable	192.168.0.21	10	1	None	30
13	Disable	192.168.0.22	10	1	None	30
14	Disable	192.168.0.23	10	1	None	30
15	Disable	192.168.0.24	10	1	None	30
16	Disable	192.168.0.25	10	1	None	30

Apply Settings
Cancel Changes

Figure 4-5-5: PD Alive Check Configuration Screenshot

The page includes the following fields:

PD Alive Check	
Object	Description
Mode	Allows user to enable or disable per port PD Alive Check function. By default, all ports are disabled.
Remote PD IP Address	This column allows user to set PoE device IP address for system making ping to the PoE device. Please note that the PD's IP address must be set to the same network segment with the 10Gbps 802.3bt PoE++ Managed Injector Hub .
Interval Time (2~300s)	This column allows user to set how long system should issue a ping request to PD for detecting whether PD is alive or dead. Interval time range is from 2 seconds to 300 seconds.
Retry Count (1~5)	This column allows user to set the number of times system retries ping to PD. For example, if we set count 2, it means that if system retries ping to the PD and the PD doesn't response continuously, the PoE port will be reset.
Action	Allows user to set which action will be applied if the PD is without any response. The 10Gbps 802.3bt PoE++ Managed Injector Hub Series offers the following 3 actions: <ul style="list-style-type: none"> ■ PD Reboot: It means system will reset the PoE port that is connected to the PD. ■ PD Reboot & Alarm: It means system will reset the PoE port and issue an alarm message via Syslog. ■ Alarm: It means system will issue an alarm message via Syslog.
PD Reboot Time (5~180s)	This column allows user to set the PoE device rebooting time as there are so many kinds of PoE devices on the market and they have a different rebooting time. The PD Alive-check is not a defining standard, so the PoE device on the market doesn't report reboot done information to the 10Gbps 802.3bt PoE++ Managed Injector Hub . Thus, user has to make sure how long the PD will take to finish booting, and then set the time value to this column. System is going to check the PD again according to the reboot time. If you are not sure of the precise booting time, we suggest you set it longer.

Table 4-5-4: Descriptions of the PD Alive Check Objects Screen

4.6 Maintenance

The Maintenance menu provides the following features for managing the system



Figure 4-6-1: Maintenance

Maintenance	
Object	Description
Administrator	Allows changing the login username and password.
Date & Time	Allows setting Date & Time function.
Save/Restore Configuration	Export the 10Gbps 802.3bt PoE++ Managed Injector Hub 's configuration to local storage. Restore the 10Gbps 802.3bt PoE++ Managed Injector Hub 's configuration from local storage.
Firmware Upgrade	Upgrade the firmware from local storage.
Reboot/Reset	Reboot or reset the system.
Auto Reboot	Allows setting auto-reboot schedule.
Diagnostics	Allows you to issue ICMP PING packets to troubleshoot IP.

4.6.1 Administrator

To ensure the 10Gbps 802.3bt PoE++ Managed Injector Hub 's security is secure, you will be asked for your password when you access the 10Gbps 802.3bt PoE++ Managed Injector Hub 's Web-based utility. The default user name and password are "admin". This page will allow you to modify the user name and passwords as shown in [Figure 4-6-2](#).

Account Password

Username	<input type="text" value="admin"/>
Password	<input type="password"/>
Confirm Password	<input type="password"/>

The password must contain 8~31 characters, including upper case, lower case, numerals and other symbols

Apply Settings
Cancel Changes

Figure 4-6-2: Administrator Web Page

Administrator	
Object	Description
Username	Input a new username.
Password	Input a new password.
Confirm Password	Input password again.

Table 4-6-1: Descriptions of the Administrator Objects Screen

4.6.2 Date and Time

This section assists you in setting the system time of the 10Gbps 802.3bt PoE++ Managed Injector Hub . You are able to either select to set the time and date manually or automatically obtain the GMT time from Internet as shown in [Figure 4-6-3](#).

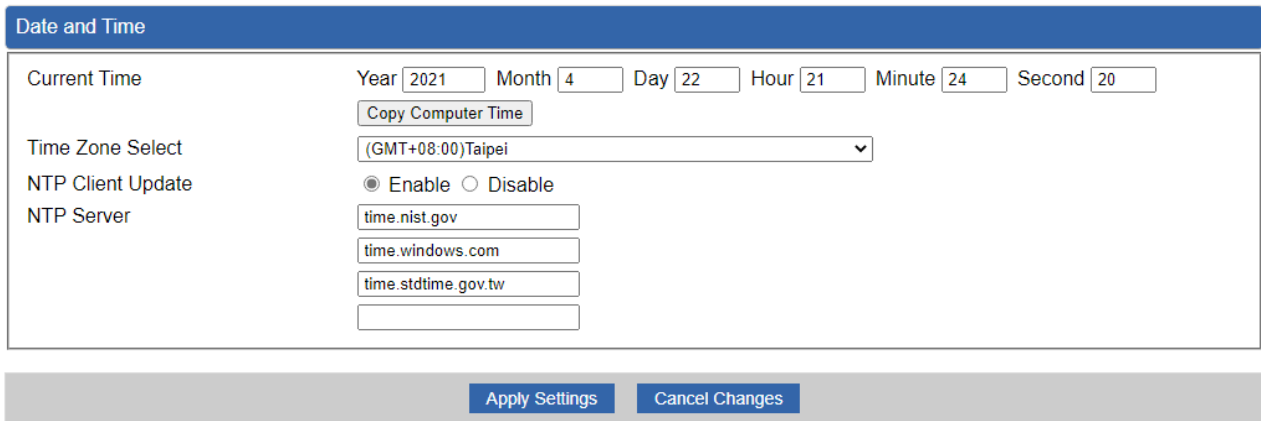

The screenshot shows a web page titled "Date and Time" with the following configuration options:

- Current Time:** Year (2021), Month (4), Day (22), Hour (21), Minute (24), Second (20). Includes a "Copy Computer Time" button.
- Time Zone Select:** A dropdown menu showing "(GMT+08:00)Taipei".
- NTP Client Update:** Radio buttons for "Enable" (selected) and "Disable".
- NTP Server:** Four input fields containing "time.nist.gov", "time.windows.com", "time.stdtime.gov.tw", and an empty field.

At the bottom of the page are two buttons: "Apply Settings" and "Cancel Changes".

Figure 4-6-3: Date and Time Web Page

Data and Time	
Object	Description
Current Time	Show the current time. User is able to set time and date manually.
Time Zone Select	Select the time zone of the country you are currently in. The 10Gbps 802.3bt PoE++ Managed Injector Hub will set its time based on your selection.
NTP Client Update	Once this function is enabled, 10Gbps 802.3bt PoE++ Managed Injector Hub will automatically update current time from NTP server.
NTP Server	User may use the default NTP sever or input NTP server manually.

Table 4-6-2: Descriptions of the Date and Time Objects Screen

4.6.3 Saving/Restoring Configuration

This page shows the status of the configuration. You may save the setting file to either USB storage or PC and load the setting file from USB storage or PC as [Figure 4-6-4](#) is shown below:

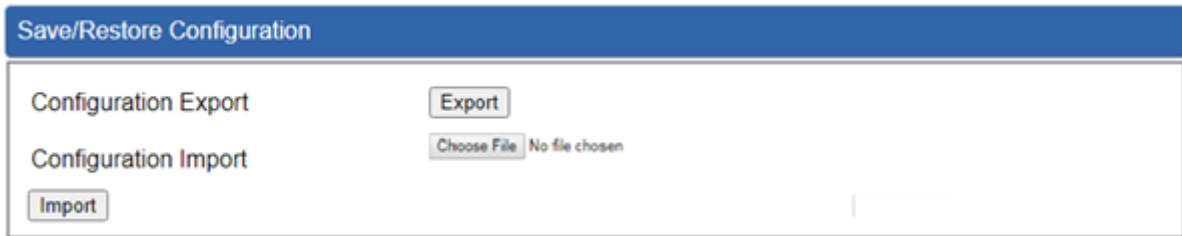

Figure 4-6-4: Save/Restore Configuration

■ Save Setting to PC



Save/Restoring Configuration	
Object	Description
Configuration Export	Press the  button to save setting file to PC.
Configuration Import	Press the  button to select the setting file, and then press the  button to upload setting file from PC.

Table 4-6-3: Descriptions of the Save/Restore Objects Screen

4.6.4 Firmware Upgrade

This page provides the firmware upgrade of the 10Gbps 802.3bt PoE++ Managed Injector Hub as shown in [Figure 4-6-5](#).

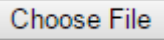
Firmware Information

Firmware Version	v1.2102b260212
Last Upgrade Date	N/A

Firmware Upgrade

Select File 沒有選擇檔案

Figure 4-6-5: Firmware Upgrade Web Page

Firmware Upgrading	
Object	Description
Choose File	Press the button to select the firmware.
Upgrade	Press the button to upgrade firmware to system.

Table 4-6-4: Descriptions of the Firmware Upgrade Objects Screen

4.6.5 Reboot/Reset

This page enables the device to be rebooted from a remote location. Once the Reboot button is pressed, users have to re-log in the Web interface as [Figure 4-6-6](#) is shown below:

Reboot / Reset

Reboot Button Reboot

Reset Button Reset to Default

I'd like to keep the network profiles.
Keep your current network profiles and reset all other configuration to factory defaults.

Figure 4-6-6: Reboot/Reset Web Page

Reboot/Reset	
Object	Description
Reboot	Press the button to reboot system.
Reset	Press the button to restore all settings to factory default settings.
I'd like to keep the network profiles.	Check the box and then press the Reset to Default button to keep the current network profiles and reset all other configurations to factory defaults.

Table 4-6-5: Descriptions of the Reboot/Reset Objects Screen

4.6.6 Auto Reboot

This page enables the device to be auto rebooted from a specific time settings, the Web interface as [Figure 4-6-7](#) is shown below:

Auto Reboot

Auto Reboot Enable Disable

Reboot Type Daily based Selected Week Day

Monday Tuesday Wednesday Thursday Friday
 Saturday Sunday

Time : (HH/MM)

Apply Settings
Cancel Changes

Figure 4-6-7: Auto Reboot Web Page

Auto Reboot	
Object	Description
Auto Reboot	Disable or enable the Auto Reboot function.
Reboot Type	Set the function type.
Time	Select reboot time for clock.

Table 4-6-6: Descriptions of the Auto Reboot Objects Screen

4.6.7 Diagnostics

The page allows you to issue ICMP PING packets to troubleshoot IP connectivity issues. After you press “Ping”, ICMP packets are transmitted, and the sequence number and roundtrip time are displayed upon reception of a reply. The Page refreshes automatically until responses to all packets are received, or until a timeout occurs. The Ping web screen shown in [Figure 4-6-8](#).

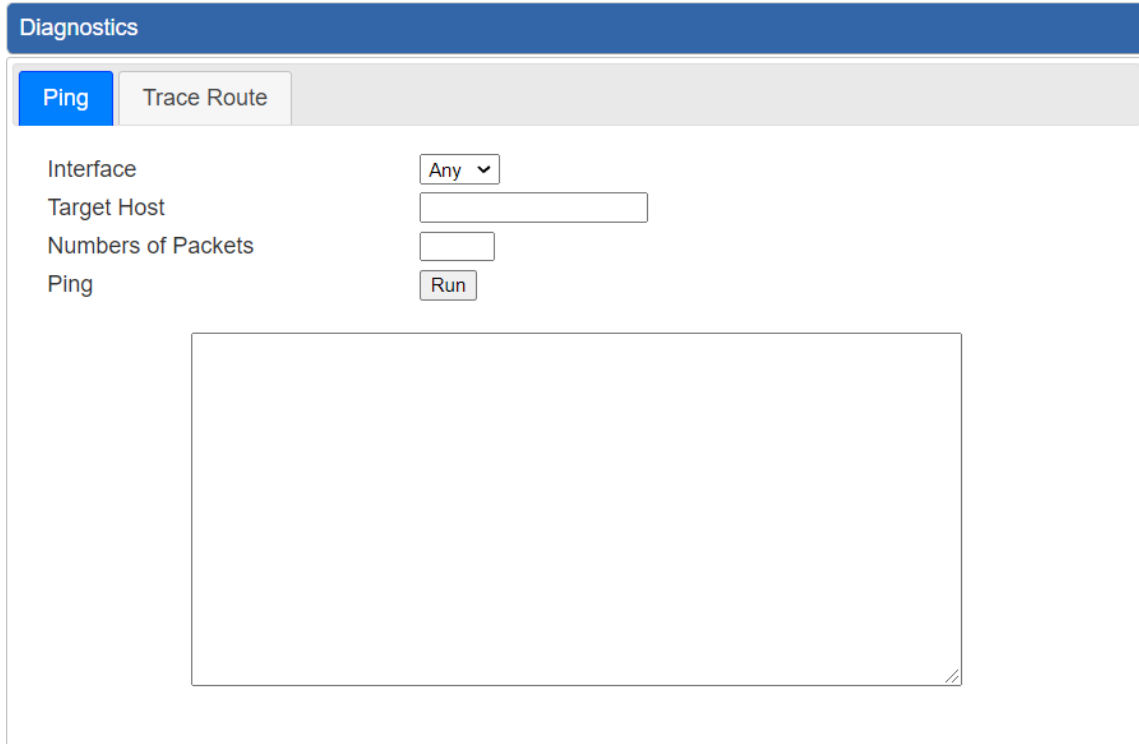

Figure 4-6-8: Ping Web Page

Diagnostics	
Object	Description
Interface	Select an interface of the 10Gbps 802.3bt PoE++ Managed Injector Hub.
Target Host	The destination IP Address or domain.
Number of Packets	Set the number of packets that will be transmitted; the maximum is 100.
Ping	The time of ping.

Table 4-6-7: Descriptions of the Ping Objects Screen

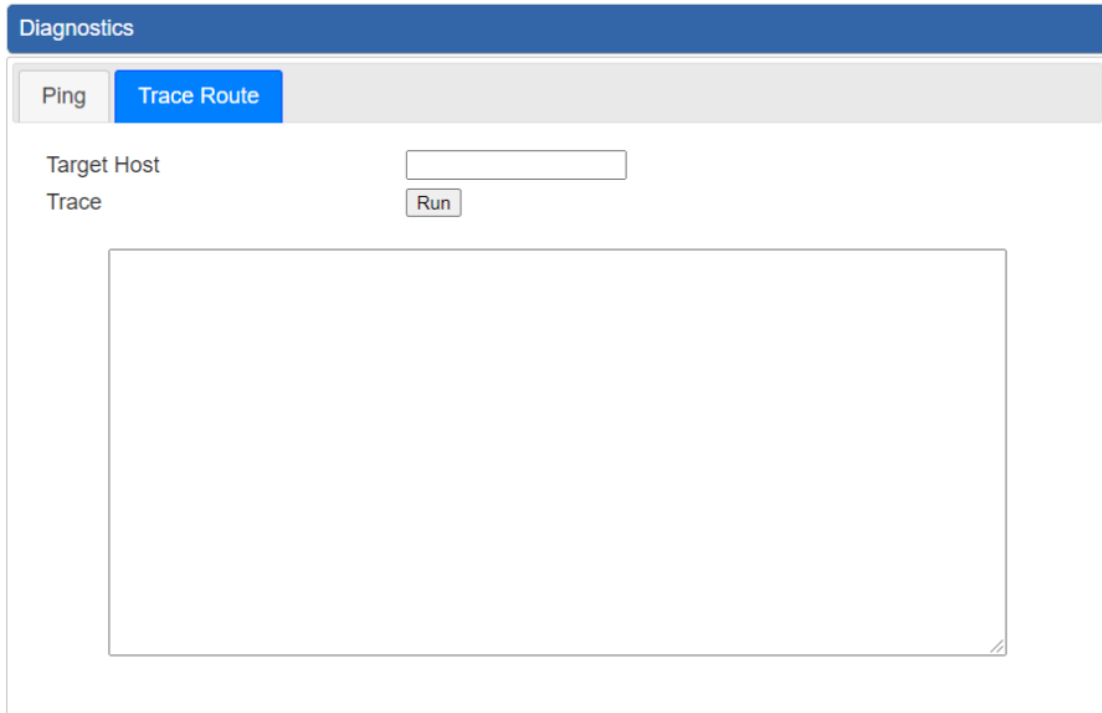

Figure 4-6-9: Trace Route Web Page

Trace Route	
Object	Description
Target Host	The destination IP Address or domain.
Trace	The time of ping.

Table 4-6-8: Descriptions of the Trace Route Objects Screen



Be sure the target IP address is within the same network subnet of the 10Gbps 802.3bt PoE++ Managed Injector Hub, or you have to set up the correct gateway IP address.

5. POWER OVER ETHERNET OVERVIEW

What is PoE?

Based on the global standard IEEE 802.3af, PoE is a technology for wired Ethernet, the most widely installed local area network technology adopted today. PoE allows the electrical power necessary for the operation of each end-device to be carried by data cables rather than by separate power cords. New network applications, such as IP Cameras, VoIP Phones, and Wireless Networking, can help enterprises improve productivity. It minimizes wires that must be used to install the network for offering lower cost, and less power failures.

IEEE802.3af, also called Data Terminal equipment (DTE) power via Media dependent interface (MDI), is an international standard to define the transmission for power over Ethernet. The IEEE 802.3af also defines two types of source equipment: Mid-Span and End-Span.

■ Mid-Span

Mid-Span device is placed between legacy switch and the powered device. Mid-Span taps the unused wire pairs 4/5 and 7/8 to carry power; the other four are for data transmission

■ End-Span

End-Span device is directly connected with power device. End-Span could also tap the wire 1/2 and 3/6.

PoE system architecture

The specification of PoE typically requires two devices: the Powered Source Equipment (PSE) and the Powered Device (PD). The PSE is either an End-Span or a Mid-Span, while the PD is a PoE-enabled terminal, such as IP Phones, Wireless LAN, etc. Power can be delivered over data pairs or spare pairs of standard CAT-5e cabling.

How power is transferred through the cable

A standard Cat5e Ethernet cable has four twisted pairs, but only two of these are used for 10BASE-T, 100BASE-T and 1000BASE-T. The specification allows two options for using these cables for power as shown in [Figure 5-1-1](#) and [Figure 5-1-2](#).

The spare pairs are used. [Figure 5-1-1](#) shows the pair on pins 4 and 5 are connected together and form the positive supply, and the pair on pins 7 and 8 are connected and form the negative supply. (In fact, a late change to the spec allows either polarity to be used).

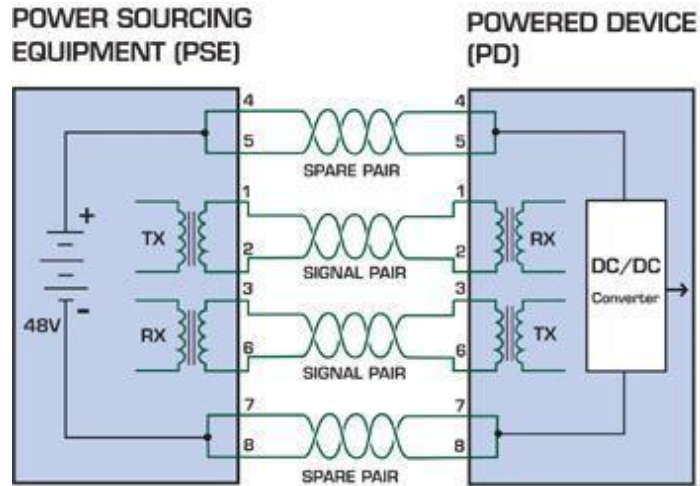

Figure 5-1-1 - Power Supplied over the Spare Pins

The data pairs are used. Since Ethernet pairs are transformer coupled at each end, it is possible to apply DC power to the center tap of the isolation transformer without upsetting the data transfer. In this mode of operation the pair on pins 3 and 6 and the pair on pins 1 and 2 can be of either polarity.

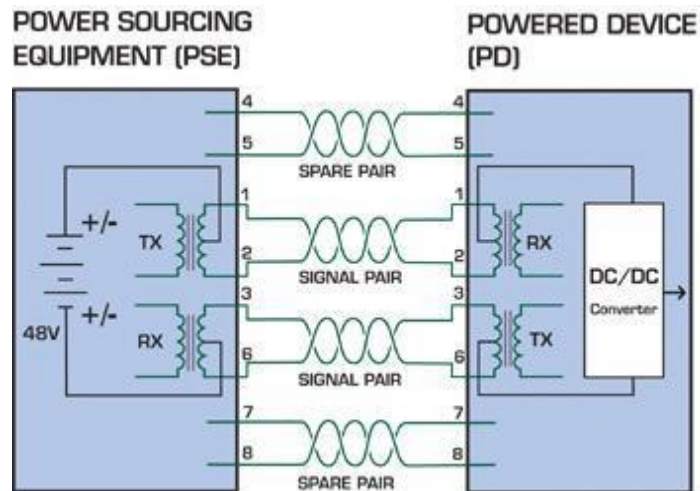

Figure 5-1-2 - Power Supplied over the Data Pins

When to install PoE?

Consider the following scenarios:

- You're planning to install the latest VoIP Phone system to minimize cabling building costs when your company moves into new office next month.
- The company staff has been clamoring for a wireless access point in the picnic area behind the building so they can work on their laptops through lunch, but the cost of electrical power to the outside is not affordable.
- Management asks for IP Surveillance Cameras and business access systems throughout the facility, but they would rather avoid another electrician's payment.

6. THE POE PROVISION PROCESS

While adding PoE support to networked devices is relatively painless, it should be realized that power cannot simply be transferred over existing Cat5e cables. Without proper preparation, doing so may result in damage to devices that are not designed to support provision of power over their network interfaces.

The PSE is the manager of the PoE process. At the beginning, only small voltage level is induced on the port's output till a valid PD is detected during the Detection period. The PSE may choose to perform classification to estimate the amount of power to be consumed by this PD. After a time-controlled start-up, the PSE begins supplying the 52V DC level to the PD till it is physically or electrically disconnected. Upon disconnection, voltage and power shut down.

Since the PSE is responsible for the PoE process timing, it is the one generating the probing signals prior to operating the PD and monitoring the various scenarios that may occur during operation.

All probing is done using voltage induction and current measurement in return.

Stages of powering up a PoE link

Stage	Action	Volts specified		Volts managed by chipset
		802.3af	802.3at	
Detection	Measure whether powered device has the correct signature resistance of 15–33 kΩ	2.7-10.0		1.8–10.0
Classification	Measure which power level class the resistor indicates	14.5-20.5		12.5–25.5
Startup	Where the powered device will start up	>42	>37.2	>38
Normal operation	Supply power to device	44-57	50-57	25.0–60.0

6.1 Line Detection

Before power is applied, safety dictates that it must first be ensured that a valid PD is connected to the PSE's output. This process is referred to as "line detection", and involves the PSE seeking a specific, 25 K Ω signature resistor. Detection of this signature indicates that a valid PD is connected, and that provision of power to the device may commence.

The signature resistor lies in the PD's PoE front-end, isolated from the rest of the PD's circuitries till detection is certified.

6.2 Classification

Once a PD is detected, the PSE may optionally perform classification, to determine the maximal power a PD is to consume. The PSE induces 15.5-25.5V DC, limited to 600 mA, for a period of 10 to 75 ms responded by a certain current consumption by the PD, indicating its power class.

The PD is assigned to one of 5 classes: 0 (default class) indicates that full 15.4 watts should be provided, 1-3 indicate various required power levels and 4 is instead of reserved has a power range of 12.95 – 25.5 watts. PDs that support classification are assigned to class 0. Special care must be employed in the definition of class thresholds, as classification may be affected by cable losses.

Classifying a PD according to its power consumption may assist a PoE system in optimizing its power distribution. Such a system typically suffers from lack of power resources, so that efficient power management based on classification results may reduce total system costs.

6.3 Start-up

Once line detection and optional classification stages are completed, the PSE must switch from low voltage to its full voltage capacity (44-57 Volts) over a minimal amount of time (above 15 microseconds).

A gradual startup is required, as a sudden rise in voltage (reaching high frequencies) would introduce noise on the data lines.

Once provision of power is initiated, it is common for inrush current to be experienced at the PSE port, due to the PD's input capacitance. A PD must be designed to cease inrush current consumption (of over 350 mA / 600mA) within 50 ms of power provision startup.

6.4 Operation

During normal operation, the PSE provides 44-57 VDC, able to support a minimum of 15.4watt / 25.5-watt power.

Power Overloads

The IEEE 802.3af / IEEE 802.3at standard defines handling of overload conditions. In the event of an overload (a PD drawing a higher power level than the allowed 12.95 watts / 25.5 watts), or an outright short circuit caused by a failure in cabling or in the PD, the PSE must shut down power within 50 to 75 milliseconds, while limiting current drain during this period to protect the cabling infrastructure. Immediate voltage drop is avoided to prevent shutdown due to random fluctuations.

6.5 Power Disconnection Scenarios

The IEEE 802.3af / IEEE 802.3at standard requires that devices powered over Ethernet be disconnected safely (i.e. power needs to be shut down within a short period of time following disconnection of a PD from an active port).

When a PD is disconnected, there is a danger that it will be replaced by a non-PoE-ready device while power is still on. Imagine disconnecting a powered IP phone utilizing 52 VDC, and then inadvertently plugging the powered Ethernet cable into a non-PoE notebook computer. What's sure to follow is not a pretty picture.

The standard defines two means of disconnection, DC Disconnect and AC Disconnect, both of which provide the same functionality - the PSE shuts down power to a disconnected port within 300 to 400ms. The upper boundary is a physical human limit for disconnecting one PD and reconnecting another.

DC Disconnect

DC Disconnect detection involves measurement of current. Naturally, a disconnected PD stops consuming current, which can be inspected by the PSE. The PSE must therefore disconnect power within 300 to 400 ms from the current flow stop. The lower time boundary is important to prevent shutdown due to random fluctuations.

AC Disconnect

This method is based on the fact that when a valid PD is connected to a port, the AC impedance measured on its terminals is significantly lower than in the case of an open port (disconnected PD).

AC Disconnect detection involves the induction of low AC signal in addition to the 52 VDC operating voltage. The returned AC signal amplitude is monitored by the PSE at the port terminals. During normal operation, the PD's relatively low impedance lowers the returned AC signal while a sudden disconnection of this PD will cause a surge to the full AC signal level and will indicate PD disconnection.

APPENDIX A

A.1 MDI Settings

The Medium-Dependent Interface (MDI or RJ45) serves as the data/power interface between Ethernet elements. As such, it has two optional connection methods to carry the power. Named Alternative A & B, Table 1 details the two power feeding alternatives.

Pin	Alternative A	Alternative B
1	Vport Negative	
2	Vport Negative	
3	Vport Positive	
4		Vport Positive
5		Vport Positive
6	Vport Positive	
7		Vport Negative
8		Vport Negative

Table -1 Alternative Table

Delivering power through an RJ45 connector's center tap ("Phantom Feeding") guarantees that bi-directional data flow is maintained, regardless of a module's power status.

A.2 Power Device Classification Values

Class	PD Current – Classification Period [mA]	PD Power – Operation Period [W]	Note
0	0 – 4	0.44 – 12.95	Default
1	9 – 12	0.44 – 3.84	Optional
2	17 -20	3.84 – 6.49	Optional
3	26 – 30	6.49 – 12.95	Optional
4	36 - 44	12.95 - 25	Optional

A.3 DATA OUT PoE Injector RJ45 Port Pin Assignments

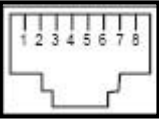
	PIN NO	10BASE-T 100BASE-TX		1000BASE-T	
	1	TX+	DC-	DA+	DC-
	2	TX-	DC-	DA-	DC-
	3	RX+	DC+	DB+	DC+
	4	-	DC+	DC+	DC+
	5	-	DC+	DC-	DC+
	6	RX-	DC+	DB-	DC+
	7	-	DC-	DD+	DC-
	8	-	DC0	DD-	DC0

A.4 RJ45 Pin Assignment of Non-802.3af/802.3at Standard PD with PoE

Mid-span PD

Pin out of Cisco non-802.3af standard PD

PIN NO	SIGNAL
1	RX+
2	RX-
3	TX+
4	VCC-
5	VCC-
6	TX-
7	VCC+
8	VCC+

Pin out of POE Mid-span

PIN NO	SIGNAL
1	RX+
2	RX-
3	TX+
4	VCC-
5	VCC-
6	TX-
7	VCC+
8	VCC+

Before you power PD, please check whether the RJ45 connector pin assignment follows IEEE 802.3af/IEEE 802.3at standard; otherwise, you may need to change one of the RJ45 connector pin assignments, which is attached with the UTP cable.